



PREWIRED SURFACE MOUNT REMOTE CONTROL INSTALLATION INSTRUCTIONS

APPLICATION

This surface mount remote control assembly is designed for use on *Evinrude[®]* and *Johnson[®]* outboards.

SAFETY INFORMATION

For safety reasons, this kit should be installed by an authorized *Evinrude[®]* / *Johnson[®]* dealer. This instruction sheet is not a substitute for work experience. Additional helpful information may be found in other service literature for your engine.

This instruction sheet uses the following signal words identifying important safety messages.

	DANGER	
Indicates an imminently hazardous situation which, if not avoided, WILL result in death or serious injury.		

	WARNING	
Indicates a potentially hazardous situation which, if not avoided, CAN result in severe injury or death.		

	CAUTION	
Indicates a potentially hazardous situation which, if not avoided, MAY result in minor or moderate personal injury or property damage. It also may be used to alert against unsafe practices.		

IMPORTANT: Identifies information that will help prevent damage to machinery and appears next to information that controls correct assembly and operation of the product.

These safety alert signal words mean:

ATTENTION!
BECOME ALERT!
YOUR SAFETY IS INVOLVED!

Always follow common shop safety practices. If you have not had training related to common shop safety practices, you should do so to protect yourself, as well as the people around you.

It is understood that this instruction sheet may be translated into other languages. In the event of any discrepancy, the English version shall prevail.

DO NOT do any repairs until you have read the instructions and checked the pictures relating to the repairs.

Be careful, and never rush or guess a service procedure. Human error is caused by many factors: carelessness, fatigue, overload, preoccupation, unfamiliarity with the product, and drugs and alcohol use, to name a few. Damage to a boat and outboard can be fixed in a short period of time, but injury or death has a lasting effect.

When replacement parts are required, use *Evinrude/Johnson Genuine Parts* or parts with equivalent characteristics, including type, strength and material. Using substandard parts could result in injury or product malfunction.

Torque wrench tightening specifications must be strictly followed. Replace any locking fastener (locknut or patch screw) if its locking feature becomes weak. Definite resistance to turning must be felt when reusing a locking fastener. If replacement is specified or required because the locking fastener has become weak, use only authorized *Evinrude/Johnson Genuine Parts*.

If you use procedures or service tools that are not recommended in this instruction sheet, YOU ALONE must decide if your actions might injure people or damage the outboard.

TO THE INSTALLER: Give this sheet to the owner. Advise the owner of any special operation or maintenance information contained in the instructions.

TO THE OWNER: Save these instructions in your owner's kit. This sheet contains information important to the future use and maintenance of your outboard.



CONTENTS OF KIT

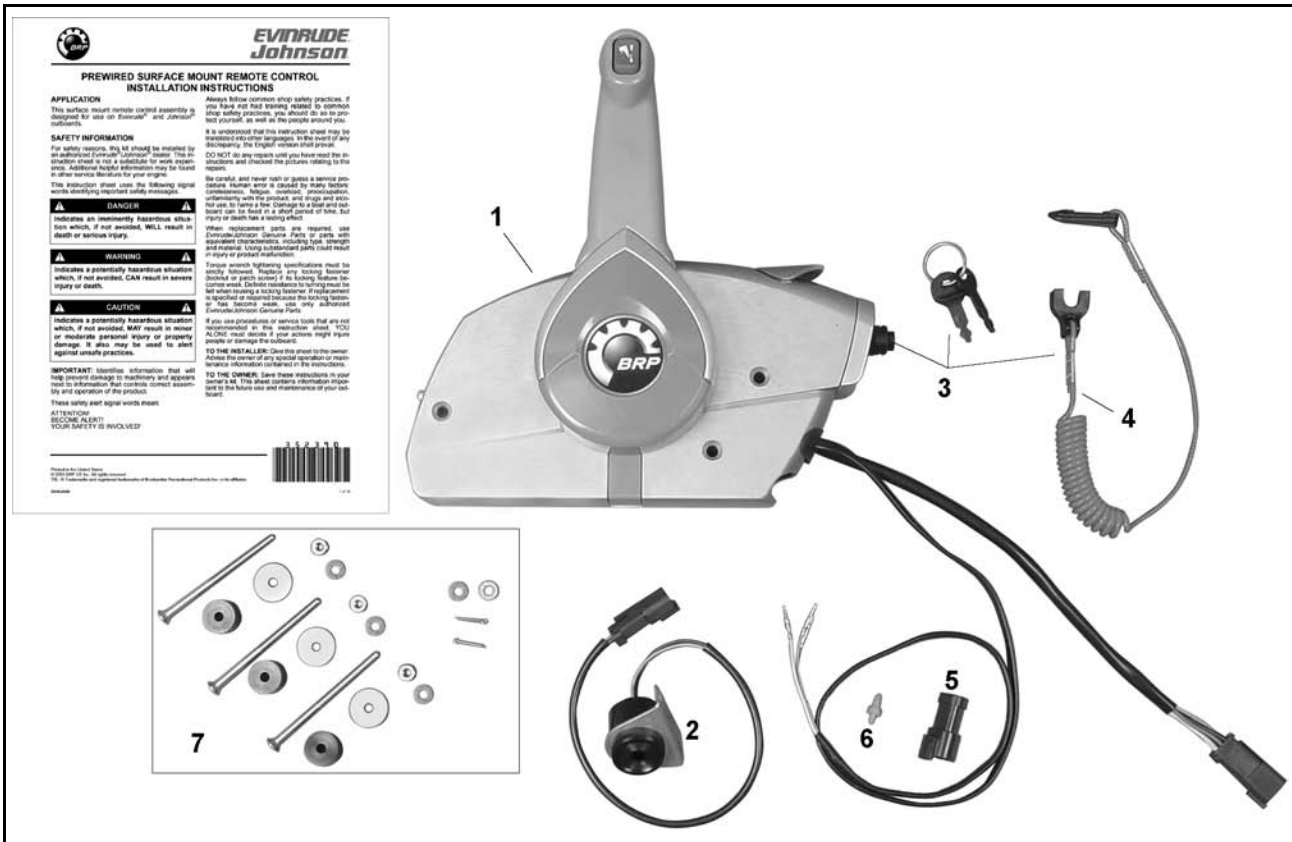

004865

Ref	P/N	Name of Part	Qty
*	5006180	REMOTE CONTROL w/ TRIM SW	
*	5006181	REMOTE CONTROL	
1	NA	*REMOTE CONTROL AY	1
2	176360	*HORN	1
3	175974	*SWITCH, KEY & LANYARD	1
4	176288	**LANYARD Assy.	1
5	514696	*CONNECTOR, 3-Pin	1
6	514697	*LOCK WEDGE, 3-Pin connector	1
7	5006550	*MOUNTING BOLT & SPACER KIT	1

REMOTE CONTROL FEATURES

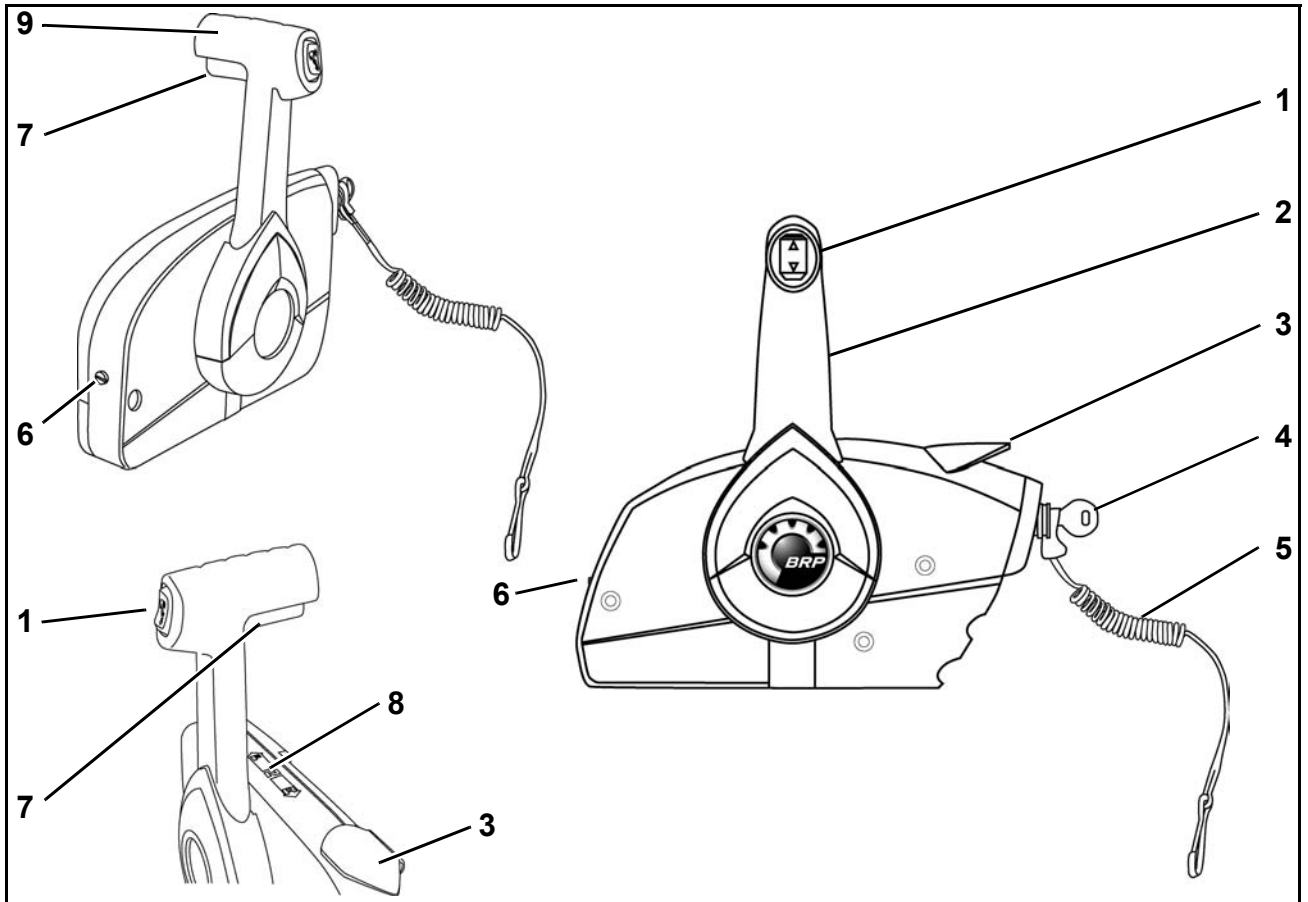

1. Trim and tilt switch
2. Remote control lever
3. Fast idle lever
4. Emergency stop / key switch
5. Clip and lanyard assembly
6. Adjusting screw, remote control lever friction
7. Neutral lock lever
8. Shift position label
9. Handle, shift and throttle

004849

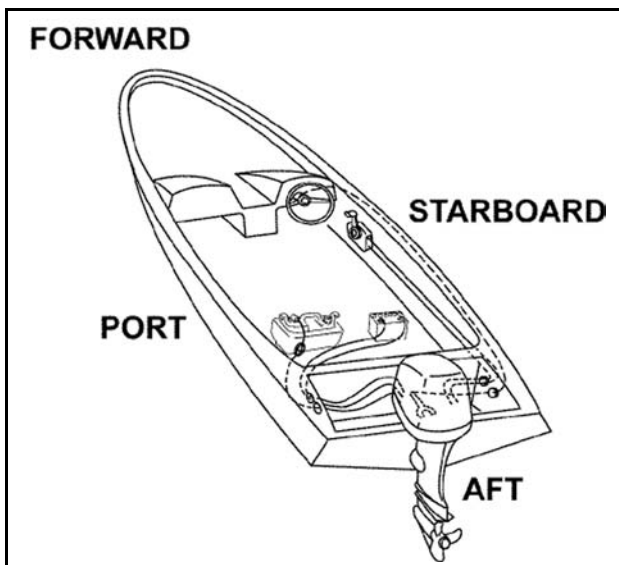

Nautical Orientation

004861

List of Features

- Neutral Lock
- “Start in gear prevention” switch
- Warning horn included
- Adjustable throttle friction
- Pigtail wiring harness – correct ignition wiring harness must be ordered separately
- Uses standard *Evinrude / Johnson* control cables (1979 and newer type)

REMOTE CONTROL OPERATION

Read and familiarize yourself with the complete operation of the remote control before attempting to start the outboard.

IMPORTANT: The operation of this remote control may vary from one outboard model to another. Refer to outboard's operator's guide for specific instructions related to outboard.

Emergency Stop Feature of Key Switch

Push clip of emergency stop lanyard onto key switch as shown.

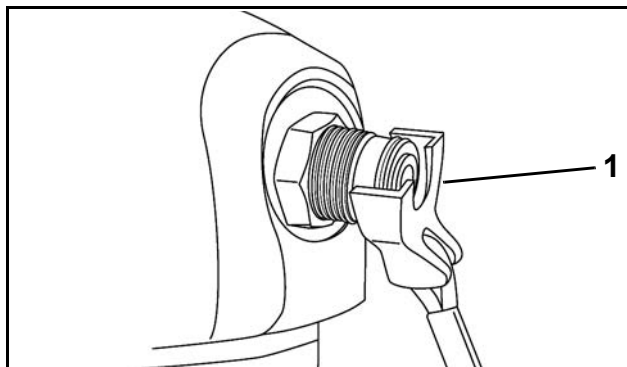

1. Emergency stop clip

004848

Lanyard **MUST** be securely attached to operator.

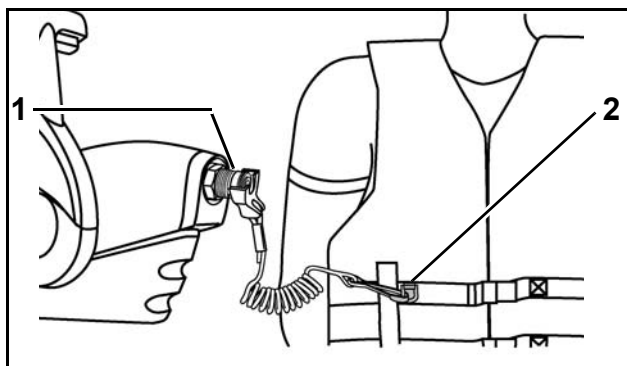

1. Key switch
2. Lanyard

004850

⚠ WARNING ⚠

Lanyard MUST be securely attached to operator, and clip MUST be installed on key switch. DO NOT operate outboard with clip removed from switch, except in an emergency.

If operator is thrown from helm, lanyard will pull clip from key switch to stop outboard.

IMPORTANT: In an emergency, a passenger can put control handle in NEUTRAL and restart outboard without lanyard.

Fast Idle Lever

Use of the fast idle lever is not required on all models. Refer to operator's guide for outboard.

The fast idle lever can be used to open throttle without shifting into gear. With control handle in NEUTRAL, lift fast idle lever to open throttle for starting and warm-up. The control is locked in NEUTRAL when fast idle lever is raised to prevent shifting into gear at higher than IDLE RPM. The control handle is unlocked when fast idle lever is all the way down.

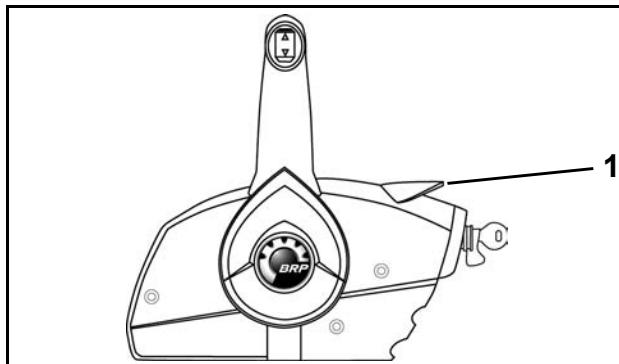

1. Fast idle lever

004851

Key Switch

Turn key switch from OFF to ON position. The warning horn should sound momentarily to indicate it is working. Turn key to START position. To use PRIME feature, push and hold key IN and turn switch to START position.

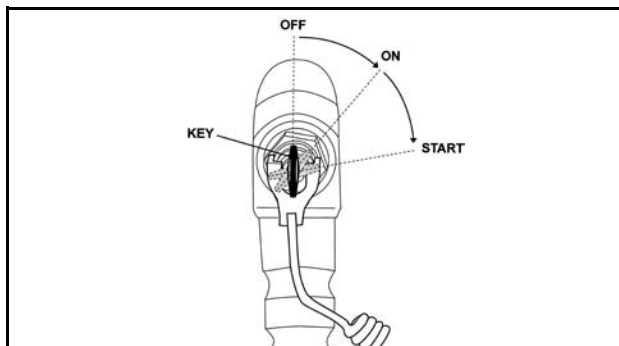

004852

Release key as soon as motor starts. **DO NOT** turn key to START while outboard is running.

Push key IN momentarily (in ON position) for additional enrichment (PRIME) to keep outboard running. Not used on all models.

DO NOT run a cold outboard any faster than necessary to keep it from stalling. **DO NOT** exceed 2500 RPM in NEUTRAL. If raised for starting, push fast idle lever part way down as soon as outboard starts. For outboards with *Quikstart*[™], wait until engine slows to IDLE RPM before shifting into gear. Refer to operator's guide for specific instructions related to outboard.

Control Handle

IMPORTANT: Outboard must be OFF. If remote control cables are connected to outboard, turn propeller shaft while shifting remote control.

With control handle in NEUTRAL and fast idle lever DOWN, lift the neutral lock lever, and move control handle to FORWARD gear or REVERSE gear position. Release neutral lock lever and continue movement of control handle in same direction to open (advance) throttle.

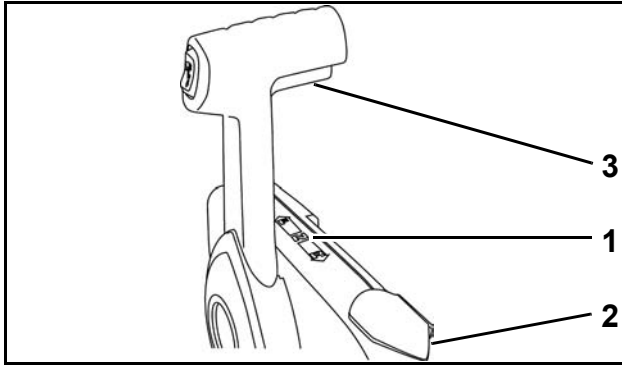

1. NEUTRAL
2. Fast idle lever
3. Neutral lock lever

004853

Refer to **Remote Control Configuration** for remote control handle set-up.

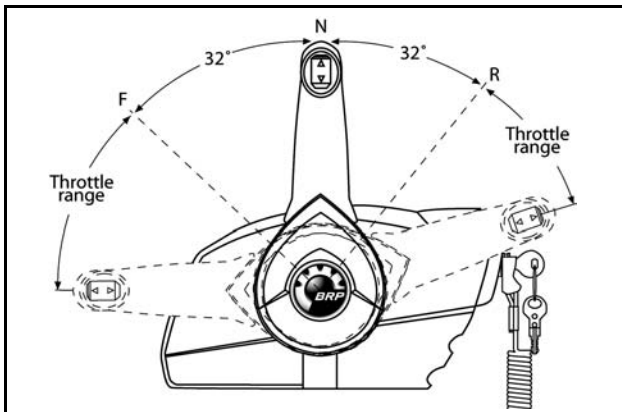

Remote Control Handle Positions

004854

Control Lever Friction Adjustment



Move the control lever to FORWARD throttle range. Control lever should move freely. Adjust control lever friction adjustment to prevent vibration from changing throttle setting.

Use a flat head screwdriver to adjust control lever friction adjustment screw. This adjustment is used to increase or reduce the force required to move the control lever.

Turn adjustment screw clockwise to increase the friction or counterclockwise to reduce the friction.

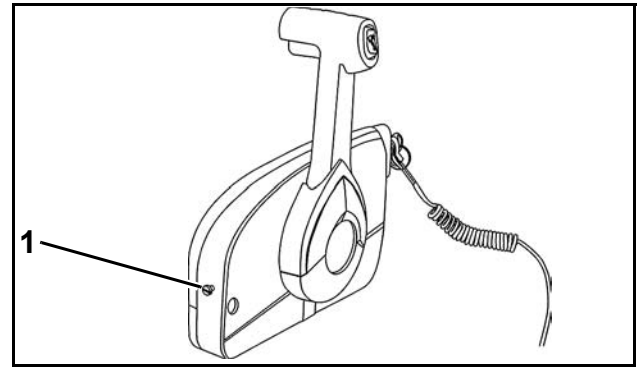

1. Adjustment screw, throttle friction

004856

Warning Horn

The warning horn sounds to alert operator when certain engine problems occur. A 1/2-second self-test beep should sound when the key switch is turned ON.

IMPORTANT: The warning horn must connect to wiring harness with a *SystemCheck™* gauge or an audible horn driver module to be functional. Refer to Operator's Guide and instrumentation instructions for additional information related to the outboard's warning system.

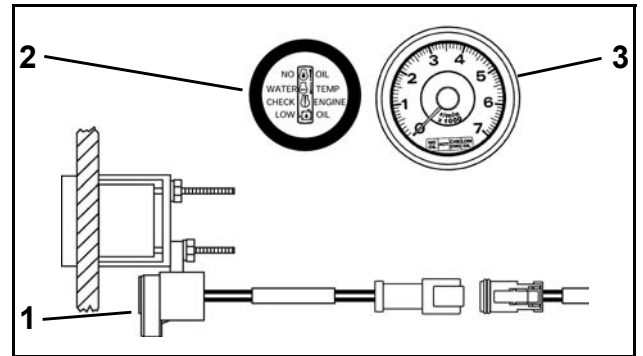

1. Warning horn
2. 2 in. SystemCheck gauge
3. 3 in. Tachometer / SystemCheck gauge

004857

Trim/Tilt Switch

Push top of switch to trim out and tilt up, or push bottom of switch to trim in and tilt down.

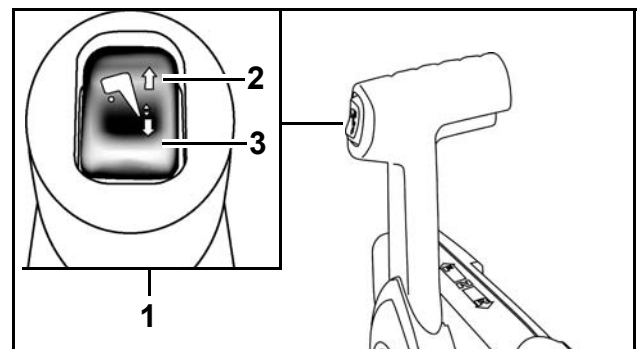

1. Trim/Tilt switch
2. Top – Trim out / tilt up
3. Bottom – Trim in / tilt down

004853

004860

INSTALLATION INSTRUCTIONS

Read and familiarize yourself with the complete installation instructions of the remote control before attempting to install the remote control. Always test operation of remote control once installed.

WARNING

Failure to properly install and test remote control may result in remote control malfunction and loss of control of boat.

IMPORTANT: Refer to specific outboard installation instructions for information related to connecting remote controls to outboard.

Select Mounting Location

This remote control can be mounted on the starboard side of the boat, or port side of center console. In the “**starboard side mount**” position, the starboard side of the control is next to the boat mounting surface.

The control can be mounted on the port side of the boat, or starboard side of center console if the control handle is relocated to the opposite side on control. In the “**port side mount**” position, the port side of the control is next to the boat mounting surface.

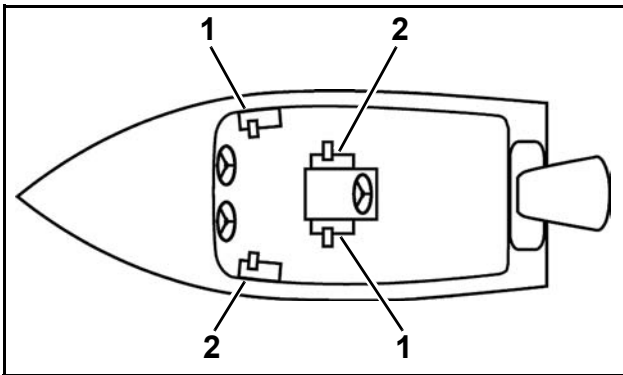

1. Starboard side mount
2. Port side mount
004855

Refer to **Remote Control Configuration**.

IMPORTANT: Remote control **MUST** be mounted where the key switch is readily accessible. Also, the mounting location must be a flat surface and must be strong enough to provide a rigid support. Strengthen mounting surface as necessary.

Place remote control at proposed location and check clearance around remote control handle at full throttle in FORWARD and then at full throttle in REVERSE. There must be at least 4 in. (10 cm) of clearance between the handle and any part of the boat throughout the control handle travel.

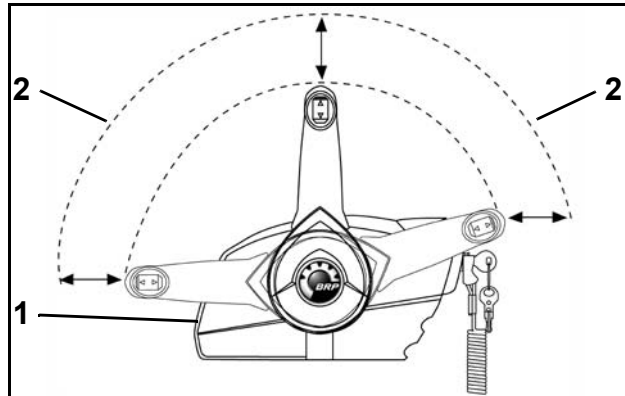

1. Remote control
2. 4 in. (10 cm) clearance line
004858

There must be at least 12 in. (30.5 cm) of clear space behind the remote control for cable routing. Control cables must be straight as they exit the remote control. Allow at least 6 in. (15.2 cm) to the beginning of the first bend of control cables.

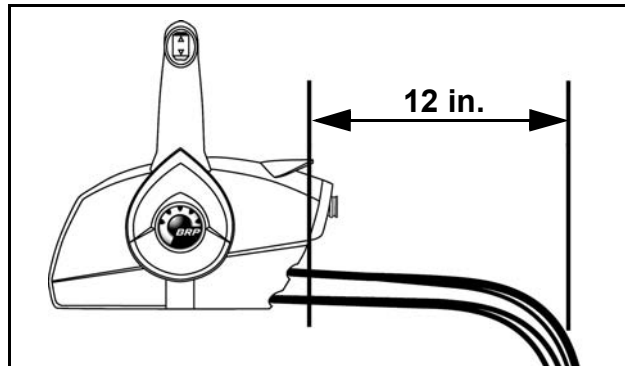

1. 12 in. (30.5 cm) clear space
004859

Determine Cable Length

Measure from center of control handle with remote control in mounting position, along intended cable route to engine centerline at transom height as illustrated by dotted lines in diagram. Add 40 in. (1.0 m) to the measurement. This dimension is the required cable length.

Evinrude/Johnson Genuine Parts outboard control cables are available in one-foot increments from 5 ft. to 20 ft. lengths and two-foot increments from 20 ft. to 50 ft. lengths. Use cables that are equal to your calculated length, or are the next longer available length.

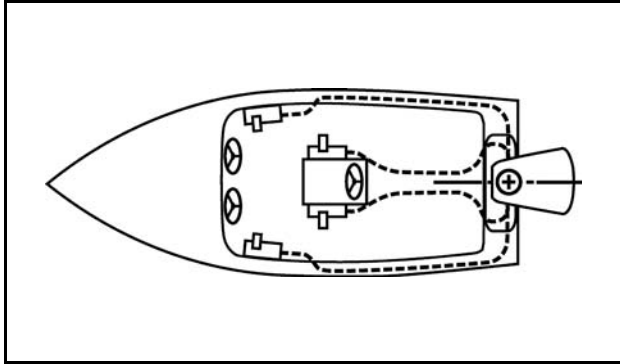

004884

IMPORTANT: Route cables with fewest number of bends. Bends must never be less than 6 in. (15 cm) radius.

Remote Control Configuration

The remote control lever can be positioned on either side of remote control, and the trim/tilt switch can be oriented to face the port or starboard side of remote control.

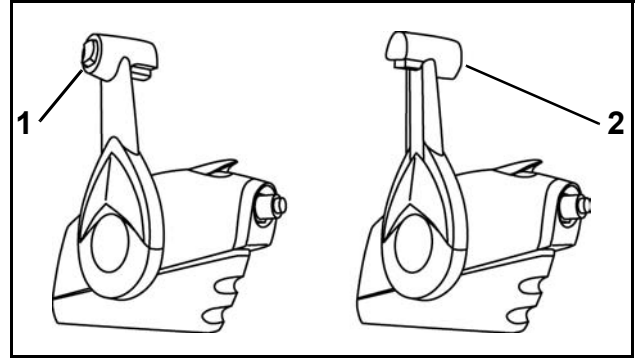

Starboard Side Mount

004862

1. Port side trim/tilt switch (standard configuration)
2. Starboard side trim/tilt switch

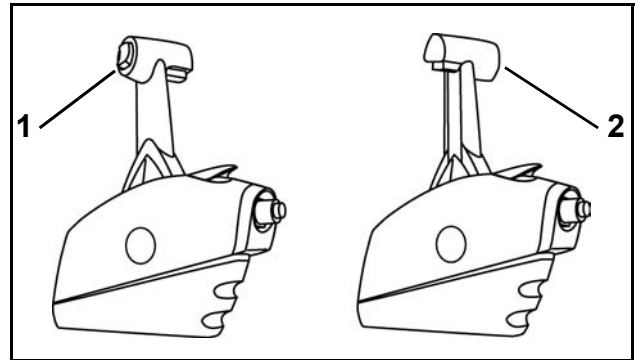

Port Side Mount

004863

1. Port side trim/tilt switch
2. Starboard side trim/tilt switch

IMPORTANT: Determine the required control handle orientation prior to installing remote control cables.

Remote Control Configuration Diagrams

IMPORTANT: Refer to the following diagrams for proper trim/tilt switch wire routing. Route the trim/tilt wiring through the correct hole in control housing to allow proper movement of lever and to prevent trim/tilt switch wire damage.

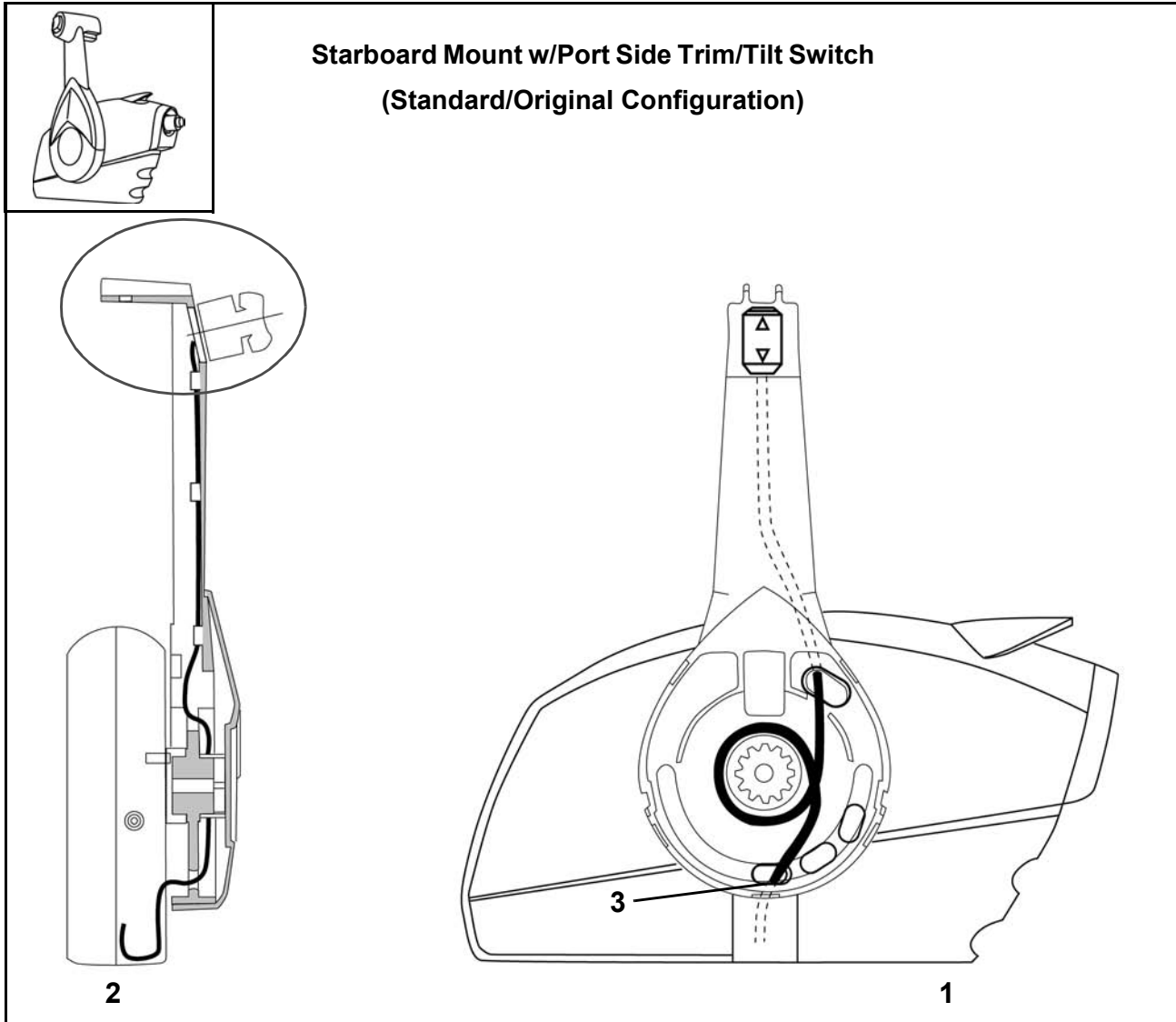

1. Port side view of remote control
2. Forward view of remote control
3. Shield

004882

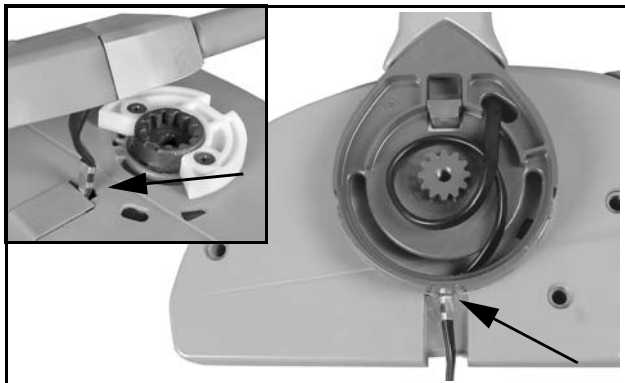

Shield

004916
004919

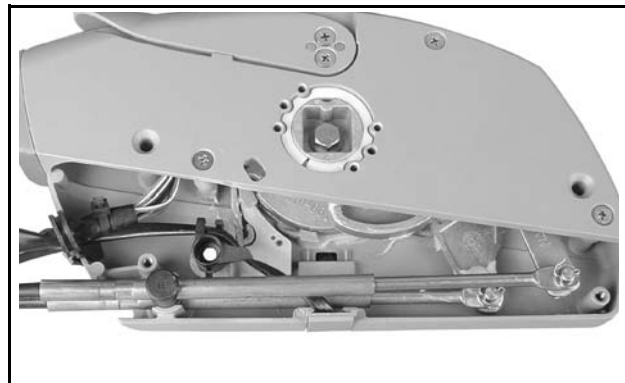

004918

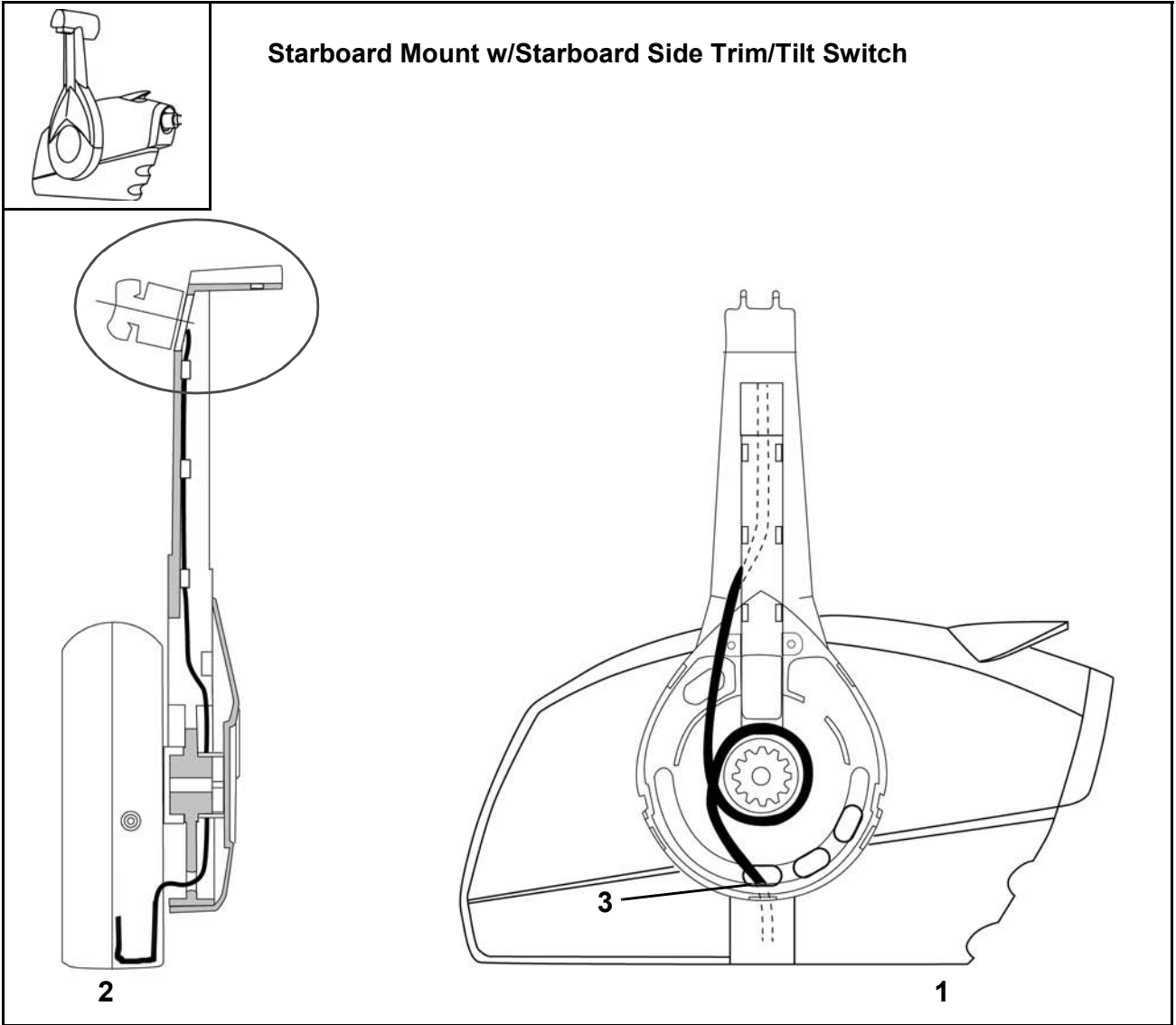

Starboard Mount w/Starboard Side Trim/Tilt Switch

- 1. Port side view of remote control
- 2. Forward view of remote control
- 3. Shield

004883

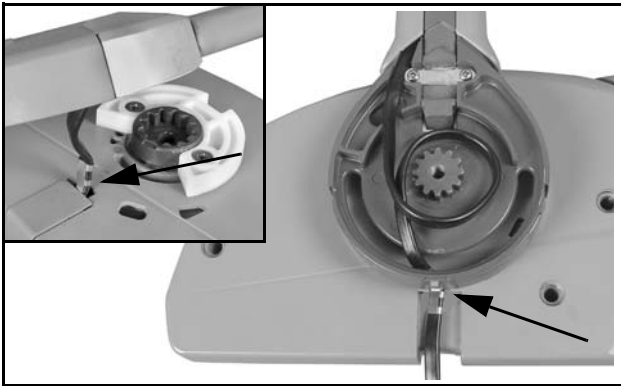

Shield

004921
004919

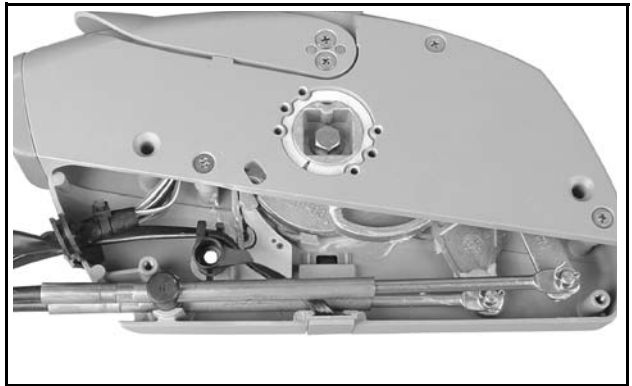

004918

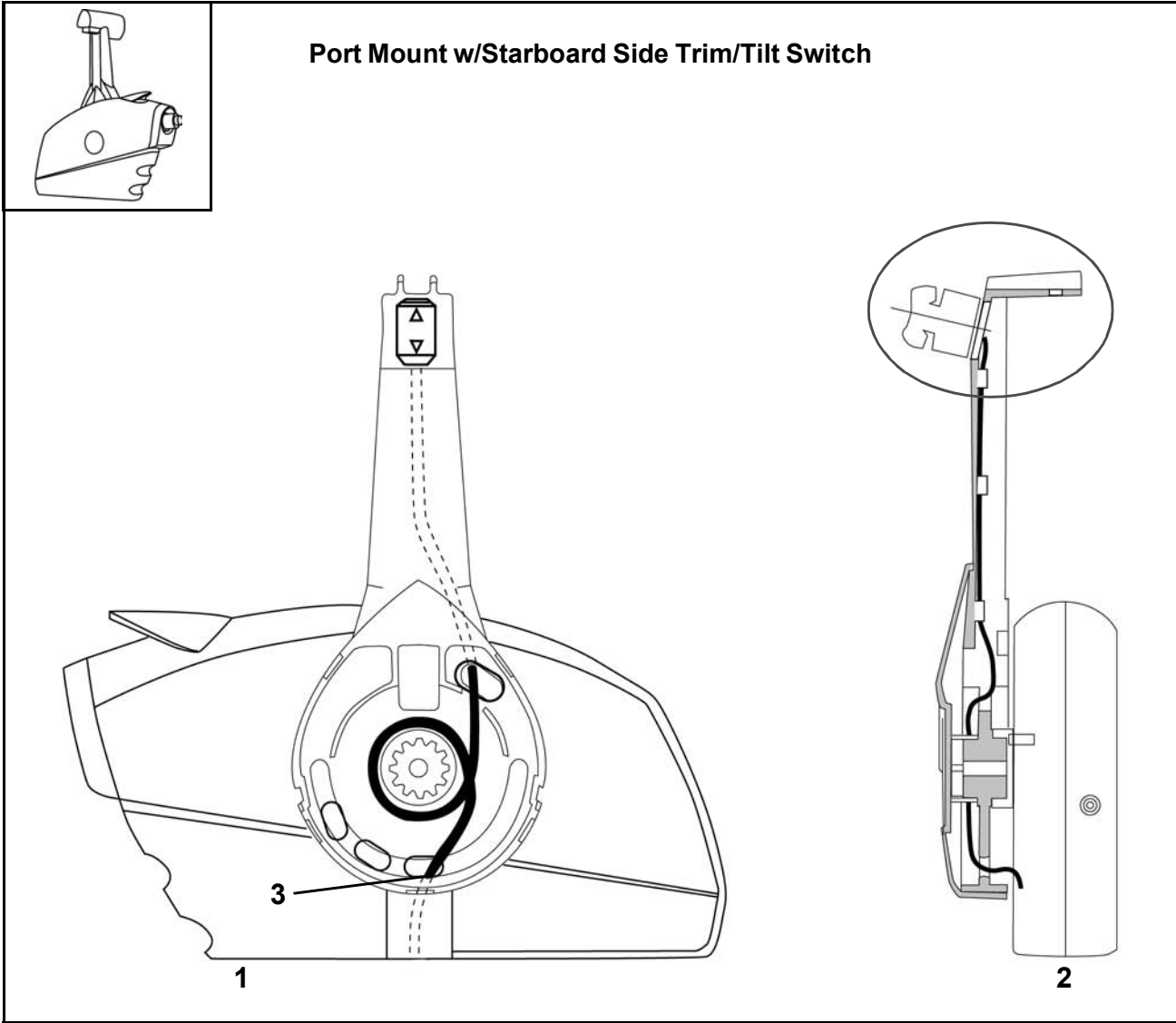

- 1. Starboard side view of remote control
- 2. Forward view of remote control
- 3. Shield

004892

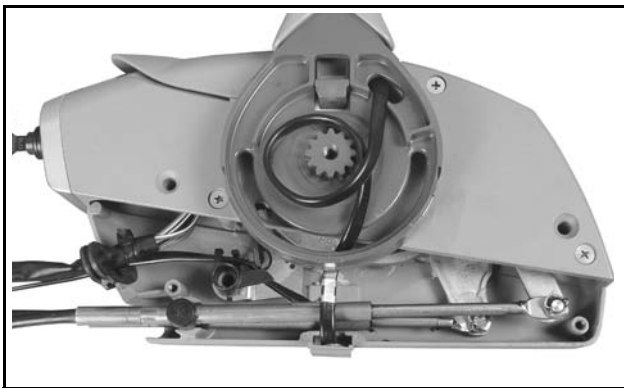

004922

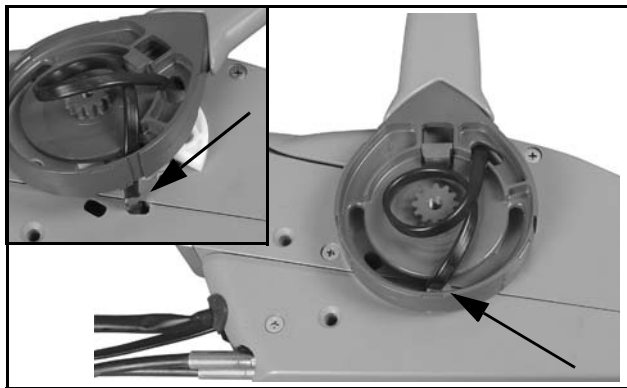

Shield

004925
004269

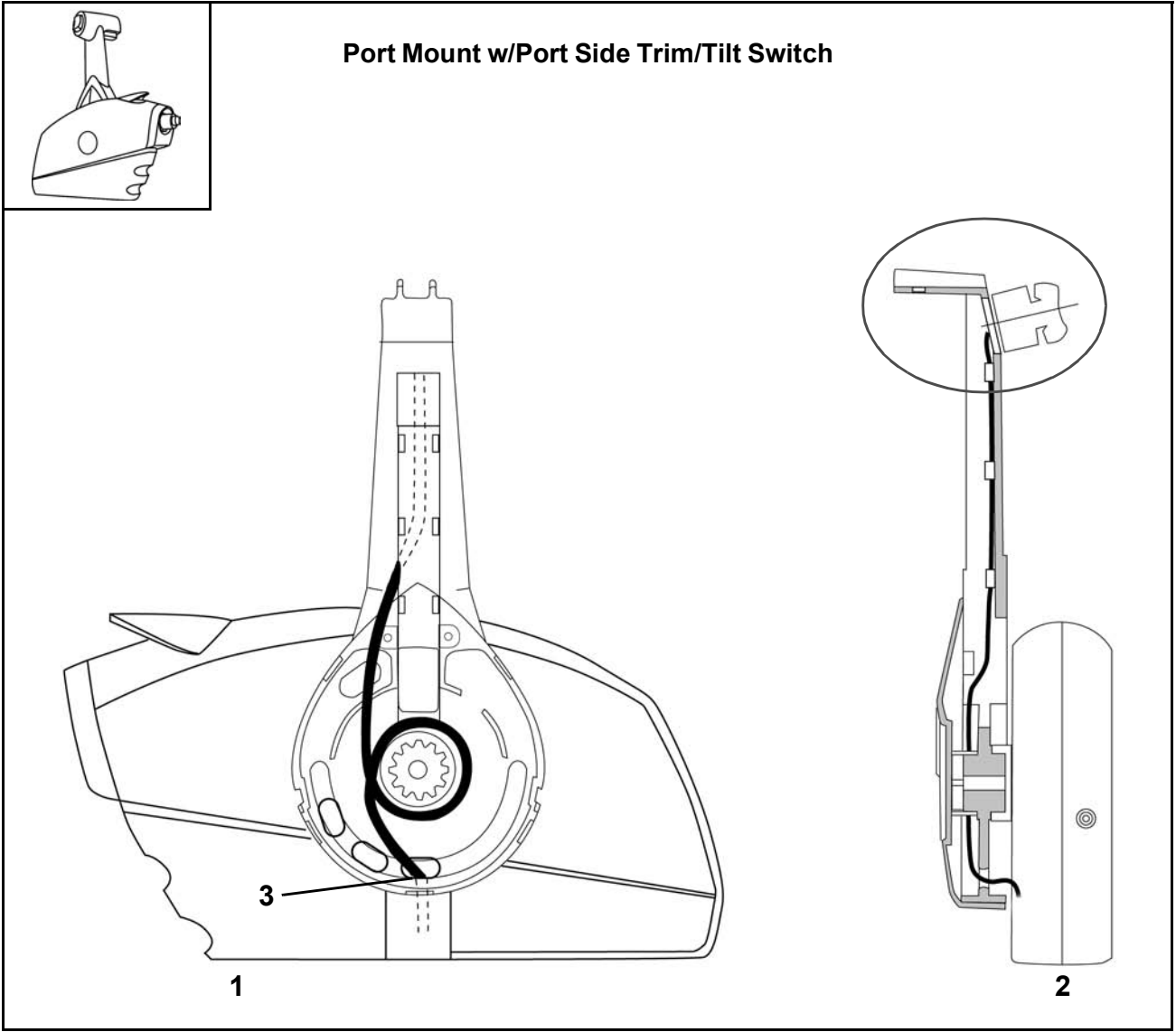

- 1. Starboard side view of remote control
- 2. Forward view of remote control
- 3. Shield

004893

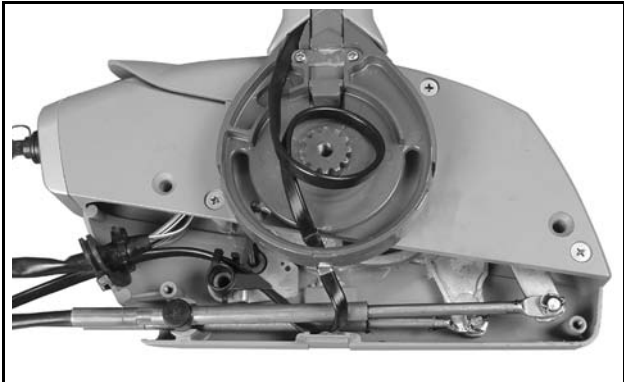

004927

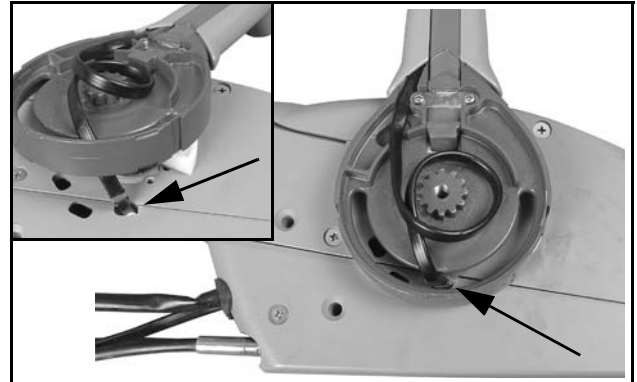

Shield

004928
004929

Control Lever Removal

IMPORTANT: Refer to **Trim/Tilt Switch Wire Routing**. Route trim/tilt wiring carefully when remote control lever and trim/tilt switch wiring are repositioned.

Refer to **Remote Control Configuration Diagrams** before performing the following steps. Remove back control cover. Compress tabs of trim wire cover to remove cover. Remove cover (standard configuration) and trim wire and retainer from remote control.

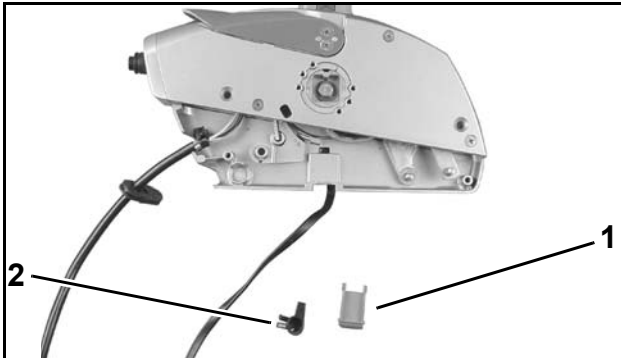

1. Trim/tilt wire cover
2. Retainer

004868

Loosen control lever retaining screw (12 mm) three to four rotations counterclockwise.

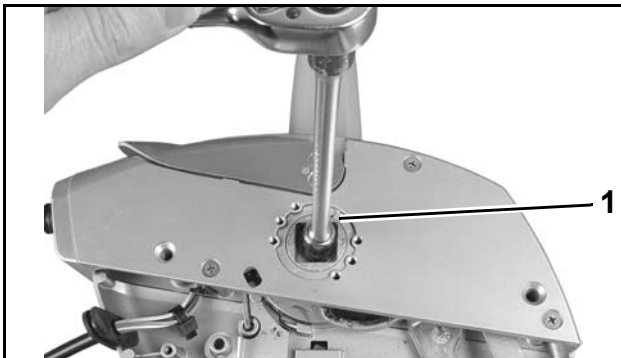

1. Lever retaining screw

004875

Support the remote control housings. Strike the screw head with a center punch and hammer to unseat control lever.

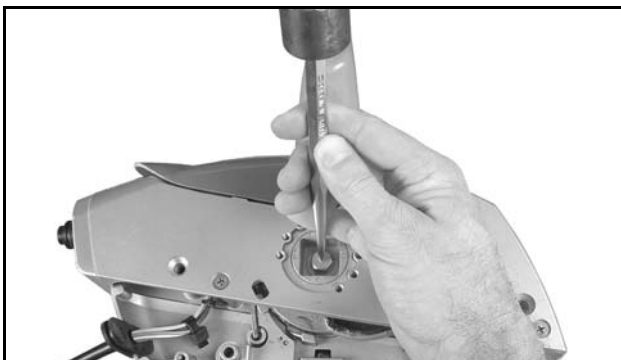

004874

Remove the screw and washer. Detach remote control lever and joint from remote control. Place flat tip screwdriver in notch of joint to pry from control.

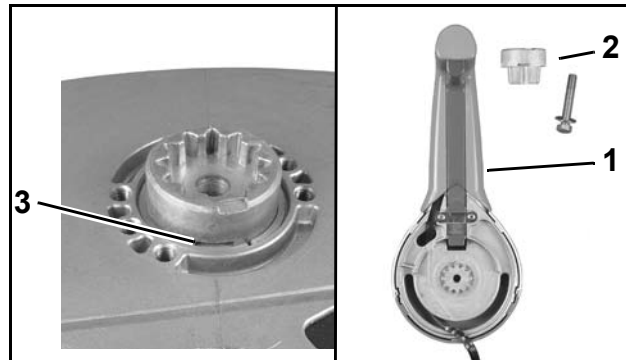

1. Lever
2. Joint
3. Notch

004878

004911

Loosen and remove two screws and neutral lock plate from remote control housing.

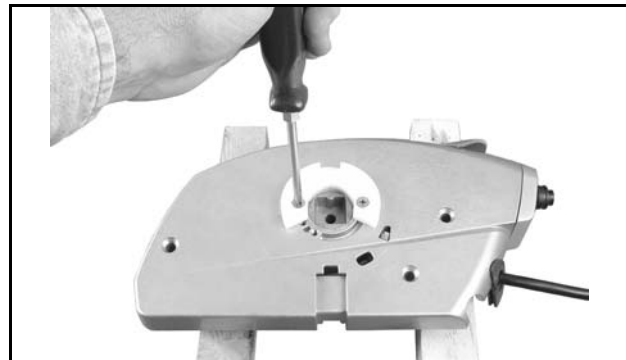

004876

Position neutral lock plate on appropriate side of remote control housing. Install two screws with lock washers through plate and torque screws to 35 in. lbs. (4 N·m).

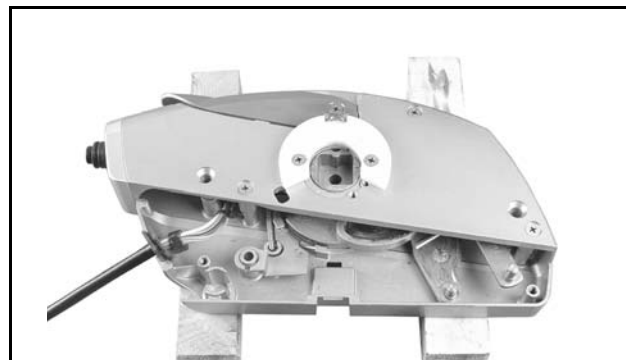

004877

Trim/Tilt Switch Wire Routing

Refer to **Remote Control Configuration Diagrams**. Note wire positions and routings.

CAUTION

To prevent trim tilt switch wiring from being damaged, route wires carefully and provide adequate slack in wiring. Refer to **Remote Control Configuration Diagrams**.

Remove control lever cover and note wire position and routing and position of wiring shield. Route wire based on diagram for your specific control lever configuration. The standard configuration is shown below (starboard side mount with port side trim/tilt switch).

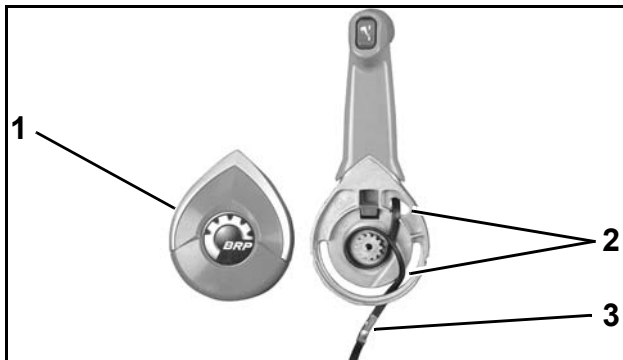

1. Cover
2. Wire routing
3. Shield

004879

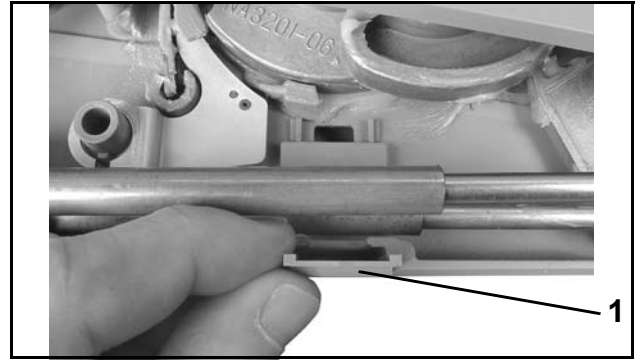

1. Cover, trim/tilt wire

004920

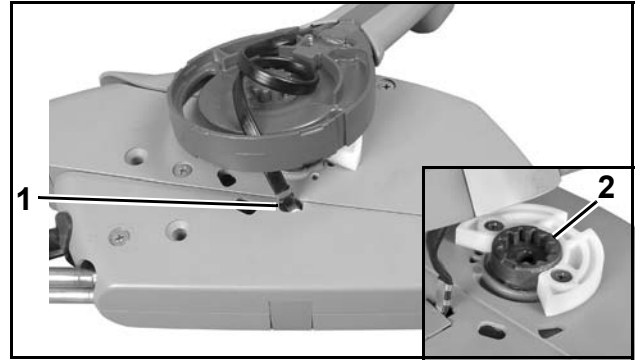

1. Wire cutout, control housing cover
2. Joint, control lever

004929
004919

Torque screws to 36 in. lbs. (4 N·m). Install remote control lever joint. Wire shield must be in position as shown. Solid side of shield must be down.

Route trim/tilt switch wires based on diagram for your specific control lever configuration. Use the trim/tilt wire retainer in all configurations. Route wire through the correct cutout of control housing cover. Refer to **Remote Control Configuration Diagrams**.

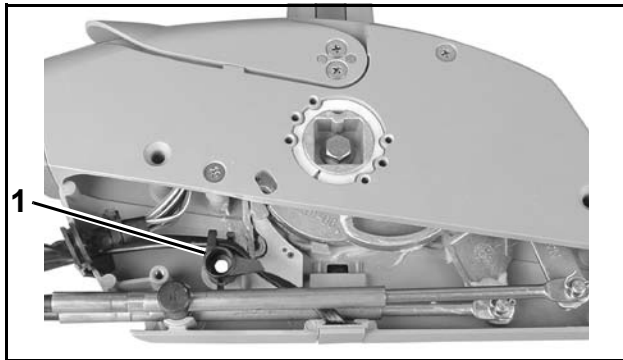

Starboard Mount Wire Routing

1. Retainer, trim/tilt wire

004918

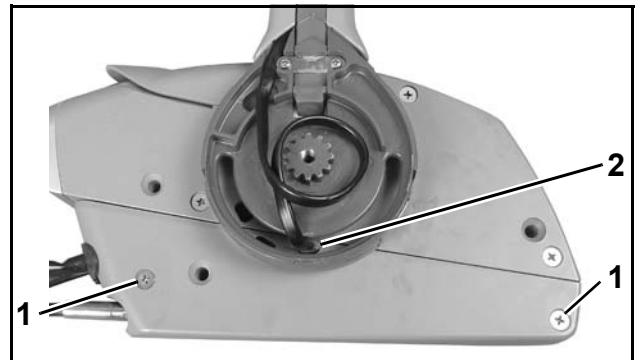

1. Screws (2)
2. Shield

004928

IMPORTANT: Remote control cables must be installed to check routing of tilt/trim wiring. Refer to **Install Remote Control Cables**.

Position lever on remote control joint. Align splines of lever with splines of joint. Neutral lock lever must align with neutral lock plate. Secure lever with screw and washer. Torque screw to 7 ft. lbs. (10 N·m).

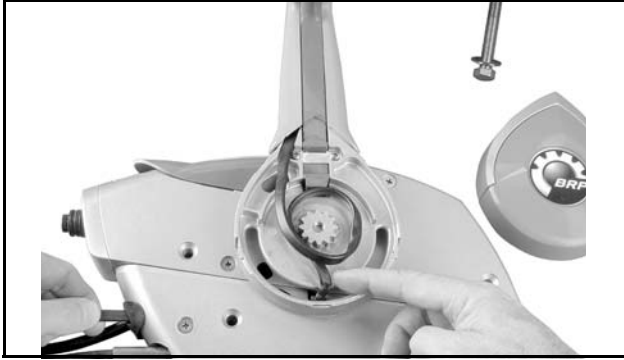

004887

Align wire and shield to prevent rubbing before installing control lever cover.

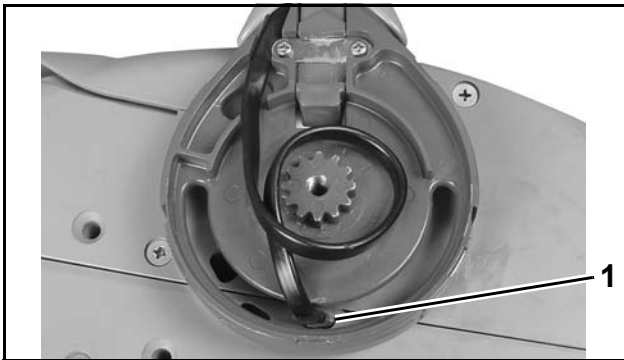

1. Shield, solid side down

0049306

IMPORTANT: Trim/tilt wire must be routed as shown in diagrams. Refer to **Remote Control Configuration Diagrams**.

Install Remote Control Cables

Remove two screws and back cover from remote control housing.

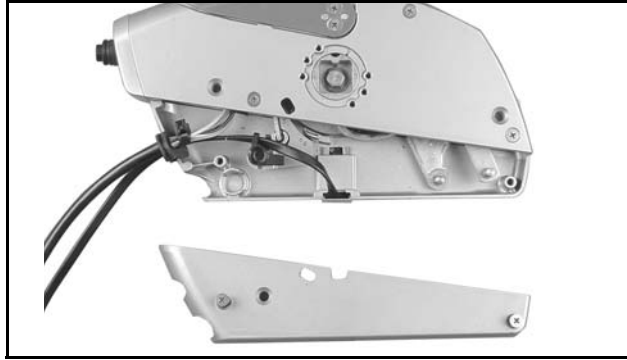

004867

Use *Triple-Guard*[®] grease to lubricate all moving mechanisms, trunnion pockets, and remote control cables.



004910

! WARNING !

Always use new cotter pins and bend both sides of cotter pin as shown to prevent interference with remote control housing or possible dislodging of cotter pin from mounting pin.

Install shift cable and flat washer on to shift pin and secure with **new** cotter pin. Bend cotter pin as shown.

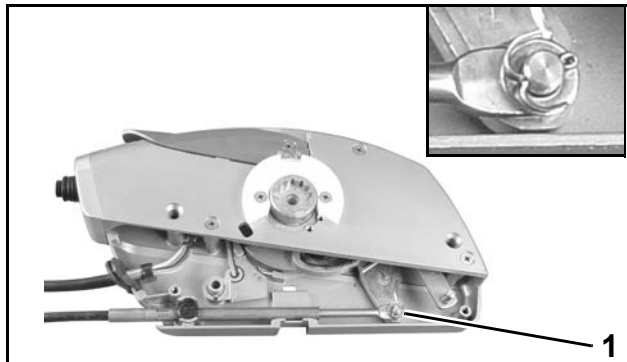

1. Shift cable

004885, 004889

IMPORTANT: Use *Evinrude/Johnson Genuine Parts* or parts with equivalent characteristics, including type, strength, and material.

Install throttle cable and flat washer on to throttle pin and secure with **new** cotter pin. Bend cotter pin as shown.

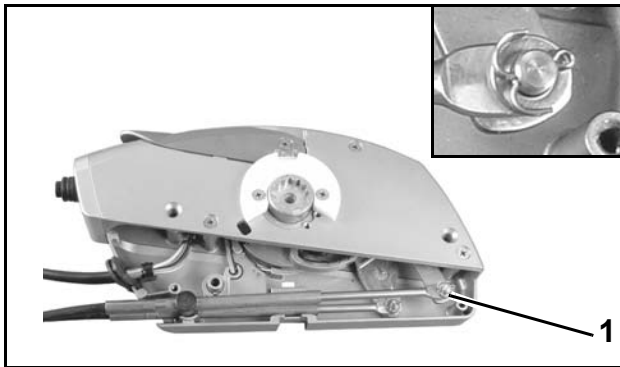

1. Throttle cable

004885, 004890

IMPORTANT: Refer to **Trim/Tilt Switch Wire Routing** before installing the remote control housing's rear cover.

Make sure shift and throttle cables are in the trunnion pockets, and trim and tilt wire is properly installed and does not rub or interfere with movements of control box components.

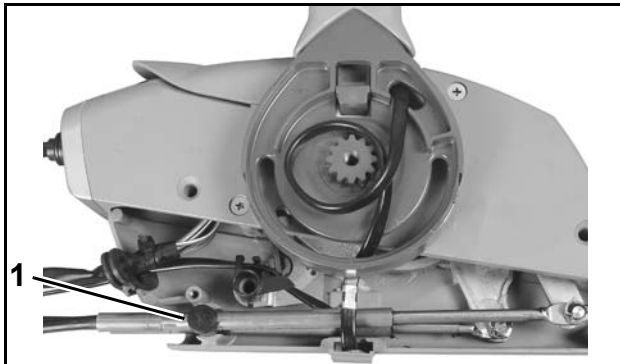

Port Mounting Configuration

1. Trunnion pockets

004922

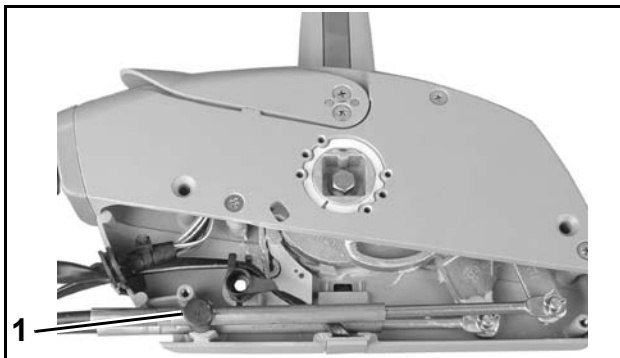

Starboard Mounting Configuration (Standard)

1. Trunnion pockets

004918

Align throttle cable trunnion and wiring grommet with back cover. Install back cover and screws. Apply *Triple-Guard* grease to assembly screws. Torque screws to 36 in. lbs. (4 N·m).

If removed, position remote control joint on drive assembly and install remote control lever.

Align splines and position lever on joint. Neutral lock lever must align with neutral lock plate. Make sure trim/tilt wire shield is in position.

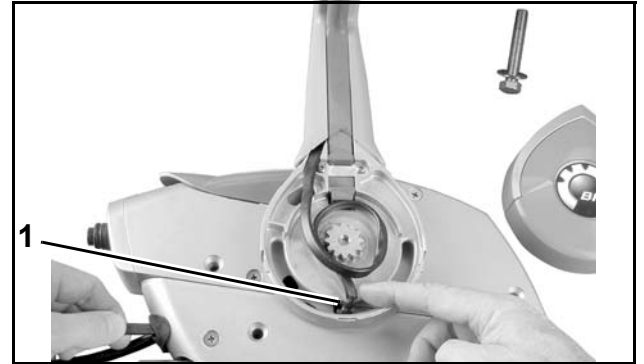

1. Shield

004887

Secure lever with screw and washer. Torque screw to 7 ft. lbs. (10 N·m). Align wire and install cover.



004899

Check operation and movement of control levers. Make sure control locks in NEUTRAL position and shift and throttle functions operate smoothly. Refer to **REMOTE CONTROL OPERATION TEST**.

Install Remote Control in Boat

Hold remote control(s) in selected position. **Refer to specific outboard installation instructions for information related to connecting remote controls to outboard.** Mark three mounting hole locations on mounting surface. Refer to profile drawing and use drill template if needed.

Drill three 1/4 in. (6 mm) holes.



1. Mounting holes, standard configuration

004900

Fasten control box in position with mounting hardware provided. Install using three each of screws, spacers, washers, lock washers, and nuts. Tighten mounting screws to 7 ft. lbs. (10 N·m).

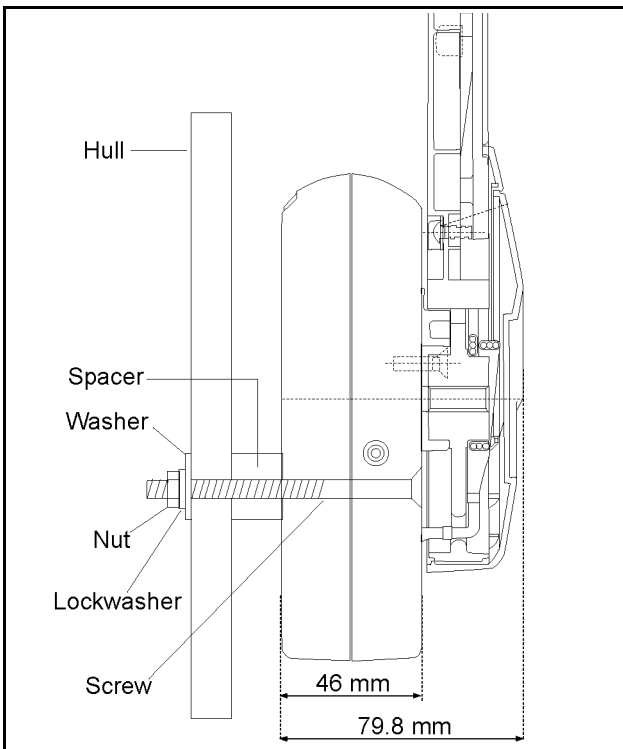

004897

IMPORTANT: After remote control is installed, check that at least three threads of the mounting screws are extended beyond the nut. Be sure remote control assembly is secure and does not move during operation.

Electrical Connections

Install trim and tilt wiring into electrical connector. Position wiring terminals in connector housing as indicated:

- Terminal for green/white wire in position "A"
- Terminal for blue/white wire in position "B"
- Terminal for red/white wire in position "C"

Insert lock, wedge after terminals are positioned in connector.

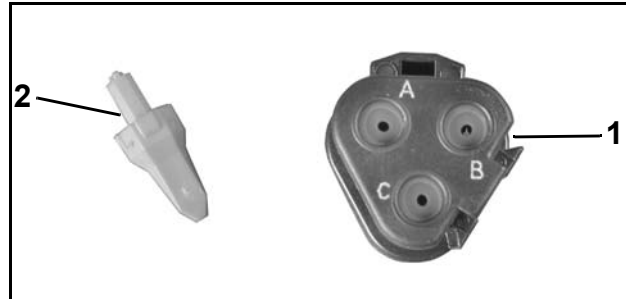

1. Electrical connector

2. Lock, wedge

004901



1. Lock, wedge

004903

IMPORTANT: Apply a light coat of *Electrical Grease™* onto the electrical connector seals. Push connectors together until latched.

Fasten warning horn bracket to mounting stud of gauge, or tie strap it to wiring harness. Carefully route wiring and connect two-pin position horn connector to two-socket horn connector of ignition harness. Connect six-pin key switch harness connector to six-socket connector of ignition harness.

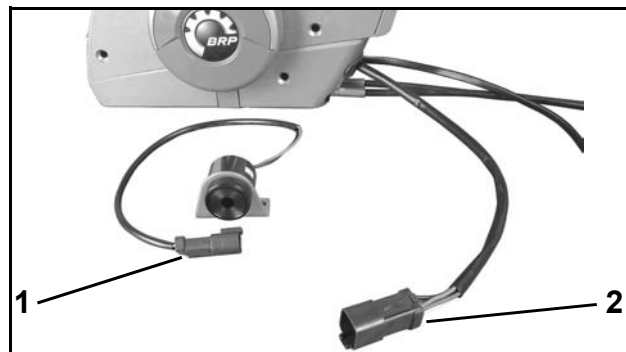

1. Horn connector

2. Key switch harness connector

004902

REMOTE CONTROL OPERATION TEST

IMPORTANT: Disconnect all spark plug wires and/or disconnect crankshaft position sensor (CPS) connector to prevent outboard from starting during test procedure. If remote control cables are connected to outboard, turn propeller shaft while shifting remote control.

Depress neutral lock lever and shift control lever into FORWARD and advance throttle to FULL THROTTLE. Next, move lever back to IDLE position and then back into NEUTRAL. Notice shift detent function of lever and make sure control lever locks at NEUTRAL position. Repeat process moving control lever into REVERSE.

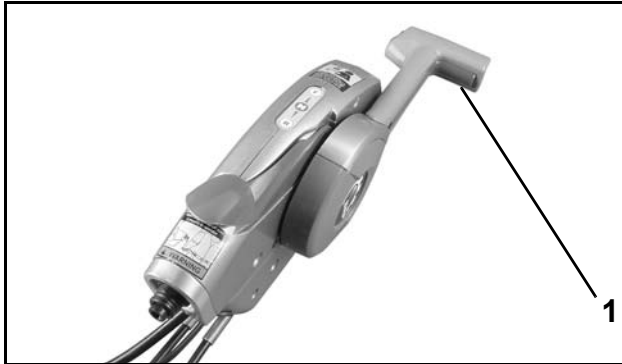

1. Neutral lock lever



004896

Remote control must shift smoothly and accurately into FORWARD, NEUTRAL, and REVERSE and throttle must move smoothly through the entire throttle range from IDLE to FULL THROTTLE (WOT). Check throttle operation in both FORWARD and REVERSE.



004904

NEUTRAL START TEST

	WARNING	
<p>Make certain starter will not operate when the outboard is in gear. The start-in-gear prevention feature is required by the United States Coast Guard to help prevent injuries.</p>		

Remote control is designed to crank outboard in NEUTRAL only.

Use this “non running” test to make certain the starter motor will **NOT** operate when control lever is in FORWARD or REVERSE.

The lanyard clip may be attached to key switch or removed for the following test.

IMPORTANT: Disconnect all spark plug wires and/or disconnect crankshaft position sensor (CPS) connector to prevent outboard from starting during test procedure.

With control lever in NEUTRAL position, turn key switch to START. The starter should operate.

With the key switch in START position and the starter cranking the engine, lift the neutral lock lever and move control lever to FORWARD. The starter should stop as lever leaves NEUTRAL.

Release key and move control lever to NEUTRAL. Turn key to START. The starter should operate.

With key switch in START position and starter cranking engine, lift neutral lock lever and move control lever to REVERSE. The starter should stop as lever leaves NEUTRAL.

OPERATOR TESTS AND ADJUSTMENTS

IMPORTANT: Test operation of emergency stop switch at each outing. Refer to **EMERGENCY STOP SWITCH TEST**. If outboard does not stop, return control to dealer for repair.

Check throttle friction. When properly adjusted, control lever should have low friction to allow easy movement in FORWARD throttle range, and not allow vibration to change throttle setting. Refer to **Control Lever Friction Adjustment**.

ON-WATER TEST



Secure boat to dock to prevent motion. Attach lanyard to key switch. Place control lever in NEUTRAL position. If needed, use fast idle lever. Turn key ON. Warning horn should sound momentarily as self-test. Turn key to START. Release key as soon as outboard starts. Push in on key for enrichment function if outboard is equipped. Do not turn key to START while outboard is running. Refer to outboard's operator's guide.

IMPORTANT: Do not exceed 2500 RPM in NEUTRAL during warm-up.

With fast idle lever all the way down, check shift operation. Check that motor shifts to FORWARD when control is shifted to FORWARD, and shifts to REVERSE when control is shifted to REVERSE.

Check that remote control operates freely and equal friction is felt in FORWARD and REVERSE throttle range of control lever.

EMERGENCY STOP SWITCH TEST

	WARNING	
<p>Always use the safety lanyard when operating boat to help prevent a runaway boat and reduce the risk of personal injury or death. Check emergency stop function often.</p>		

Check emergency stop function. Install lanyard clip on key switch and start outboard.

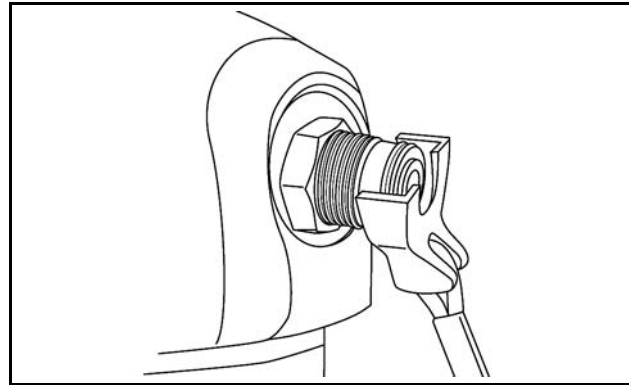

004848

With outboard running, remove emergency stop lanyard. Outboard must STOP. If outboard does not stop, check key switch and wiring. Repair as needed.

MAINTENANCE

CAUTION

Inspection and maintenance must be performed with outboard stopped. Disconnect emergency stop lanyard, disconnect battery cables, and remove spark plug wires from spark plugs to prevent accidental starting of outboard.

Check mounting of remote control. Tighten screws or secure as needed.



Port Mounting Configuration
1. Screws (3)

004912

While turning propeller, check for smooth and correct operation of remote control. Observe linkages at outboard and be sure shift and throttle linkages move accurately and completely for each remote control setting.

If an abnormal condition is found, repair as needed. Replace all damaged parts. Recheck operation of remote control after servicing. Remote control must shift smoothly and accurately into FORWARD, NEUTRAL, and REVERSE, and throttle must move smoothly through the entire throttle range from IDLE to FULL THROTTLE (WOT). Check throttle operation in both FORWARD and REVERSE.

Check remote control for looseness, damage, and corrosion. Clean and replace parts as needed.

Use *Triple-Guard* grease to lubricate all moving mechanisms and remote control cables.

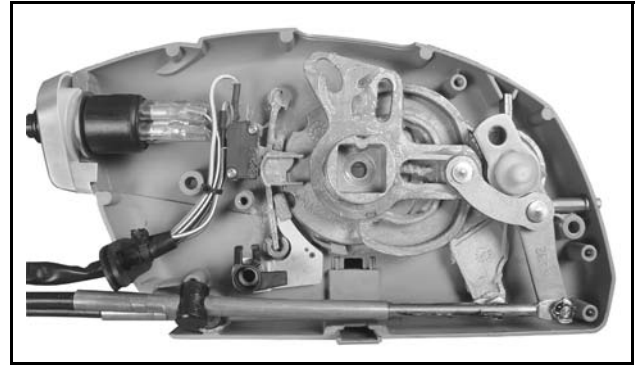

004914

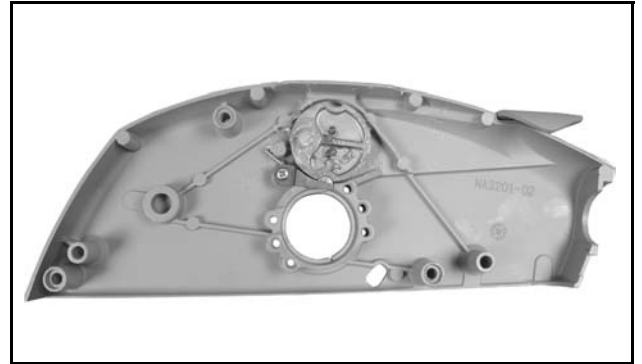

004915

Reassemble all components disassembled for inspection and servicing. Check operation of remote control.

Start outboard and check shift and throttle operation.

With outboard running, remove emergency stop lanyard. Outboard must STOP. If outboard does not stop. Check key switch and wiring. Repair as needed.

Surface Side Mount Control P/N 5006180/5006181

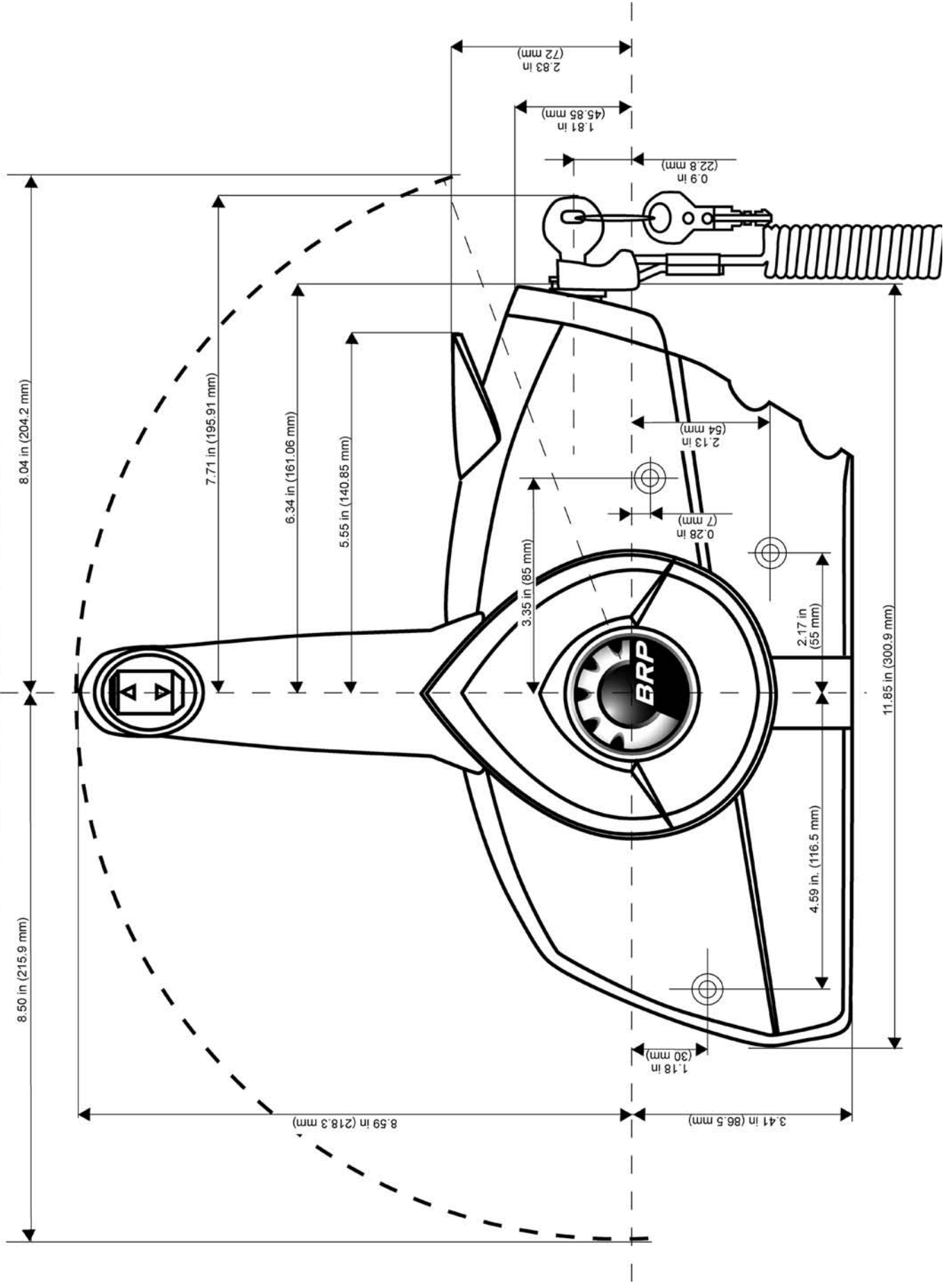

Surface Side Mount Control
P/N 5006180/5006181

Drill Template

