

Water Pump Replacement for BF8D • BF9.9D Outboard Motors

Prior to removing the gear case, make sure the outboard motor is secure on an engine stand or transom of a boat that is out of the water. Tilt the outboard motor up to the highest position and place the shift lever in the "R" (Reverse) position.

Record the number of threads exposed on shift rod B before loosening the lock nut. This is necessary to ensure the adjusting nut is returned to the same position.

Number of threads exposed: _____

With two 10 mm open-end wrenches, loosen the lock nut and back the adjusting nut off until the shift rods separate.

During reassembly, if the original position of the lock nut was not recorded, set the lock nut to 0.3 inches (8 mm) from the end of shift rod B, and then tighten the adjusting nut to the lock nut.

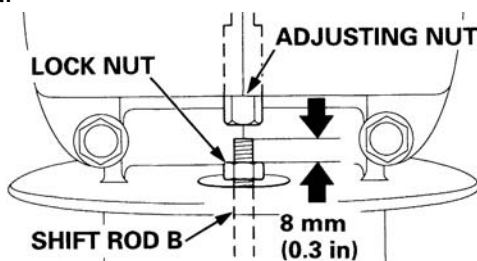

With a 10 mm wrench, remove the 6 x 75 mm and four 6 x 23 mm flange bolts from the gear case assembly. The vertical shaft and shift rod B will stay connected to the gear case, so remove the gear case without twisting, and then place the unit on a workbench.

Using a 10 mm wrench, remove the four 6 x 50 mm washer bolts attaching the water pump. Gently pry the pump housing and remove it from the vertical shaft.

Clean all parts and check the impeller, liner, and cover for wear or cracks.

TYPE KIT	CONTENTS	PART NUMBER
1 - Service kit	Impeller, O-ring, gasket, key	06192-ZW9-000
2 - Rebuild kit	Housing, liner, impeller, water tube seal ring, O-ring, cover, key, gasket, washer bolt (4)	06193-ZW9-020

Use the service kit [1] if only the impeller is worn.
Use the rebuild kit [2] if the liner and/or the impeller cover are worn

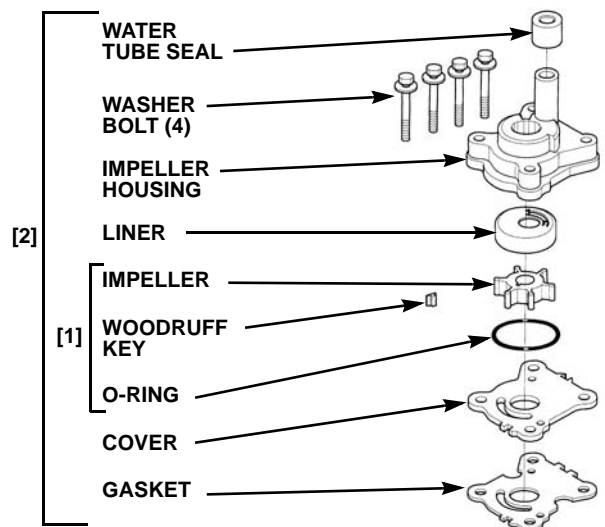
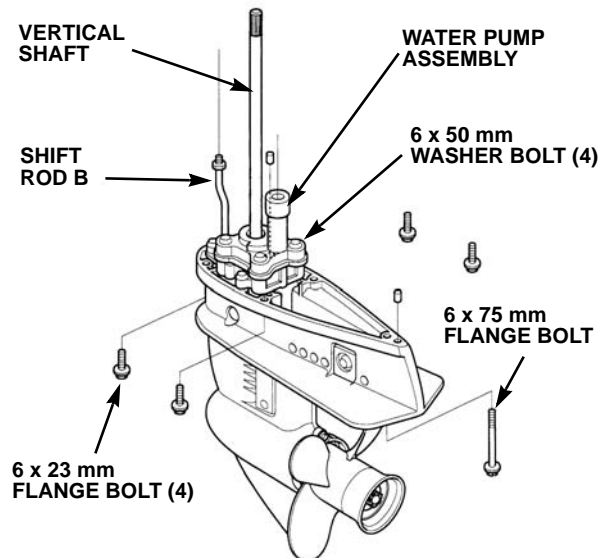
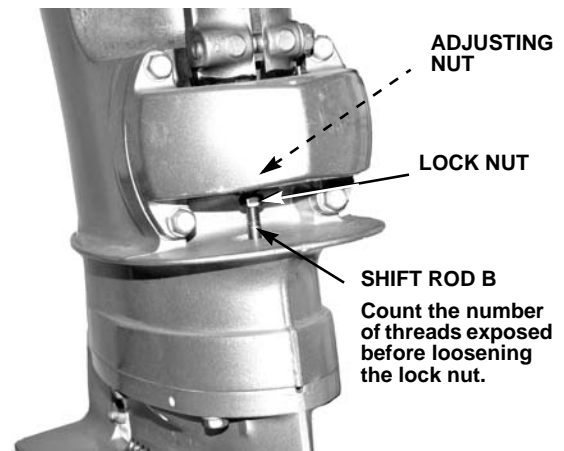

Start reassembling the pump by applying marine grease to the inner surface of the impeller liner, housing O-ring, and the water tube seal ring.

Install the impeller by turning it counterclockwise into the impeller liner. Make sure the open end of the keyway is visible and will face out when installed in the pump.

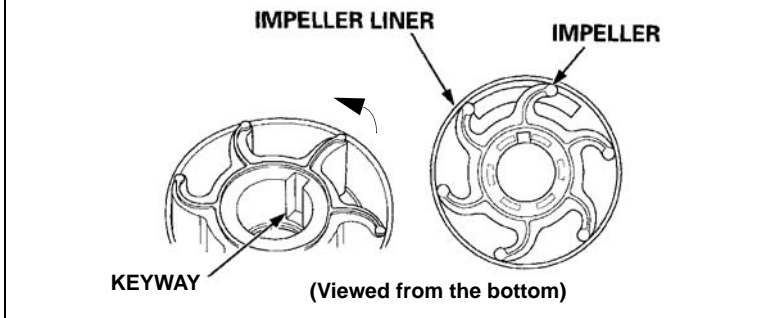

Align the boss of the impeller liner and insert into the groove of the impeller housing. Insert a new greased O-ring and water tube seal ring into the impeller housing.

Install the impeller gasket and cover by aligning the cutout with the boss of the water pump housing.

Place a small amount of marine grease on the Woodruff key and insert it onto the flat surface of the vertical shaft.

Slide the impeller housing assembly over the shaft, making sure to align the Woodruff key with the impeller keyway.

Install the four 6 x 50 mm washer bolts and torque to **8.0 ft•lb (11 N•m)** in a crisis-cross pattern to make sure the housing seats correctly.

Apply marine grease to the vertical shaft splines and two dowel pins, and then install the gear case assembly into the motor.

If needed, turn the prop clockwise to align the vertical shaft splines. Make sure the water tube seal ring has been greased for ease of installation.

Start threading the 6 x 75 mm and four 6 x 23 mm flange bolts to hold the gear case in place.

Attach the adjuster nut to shift rod B until contact is made with the lock nut. Tighten the lock nut against the adjuster nut so the same number of threads are visible as recorded during disassembly. See previous page.

Torque the five 6 mm gear case bolts to **9 ft•lb (12 N•m)**.

Make sure that the shift lever moves smoothly into all positions.

