



Mounting Instructions and Template for Model 75019 Quick Release Track

Form 12.169

ASSEMBLY INFORMATION

1. Check parts against parts list.
2. Read Instructions completely before starting assembly.
3. NOTE: This product uses locknuts for a secure assembly. Locknuts thread on harder than conventional nuts and require a screwdriver and wrench for attachment.

TOOLS REQUIRED

1. Wrench adjustable to 7/16"
2. Screwdriver
3. Drill

TRACK MOUNTING INSTRUCTIONS

1. Position template on reverse side of Instruction sheet for plastic tracks (A) on seat bench to locate securing points for drilling. Mark end drill the six holes.
2. Position plastic tracks (A) as shown in Fig. 1. Use bolts or screws best suited for your boat to secure tracks.

TO ADAPT MODEL 75018 SWIVEL FOR USE WITH MODEL 75019 QUICK RELEASE TRACK SYSTEM

1. Place spring (B) on locking handle (C) as illustrated in Fig. 2.
2. Slide locking handle with attached spring over end of model 75018 swivel as indicated in Fig. 3. The end of the swivel must be sandwiched between the spring and the locking handle as illustrated.
3. Align holes of locking handle, swivel end and spring; then insert screw (D) through them as illustrated in Fig. 3. Slip bushing (E) and washer (F) over threads of screw (D). Secure bushing end washer onto screw with nut (G). Finger tighten only.

(over)

Parts List			
Ref. Letter	Factory Part No.	No. Req.	Description
A	06.096	2	Plastic track
B	49.111	1	Spring
C	59.038	1	Locking handle
D	03.174	1	1/4-20 x 3/4" machine screw
E	08.020	1	Bushing
F	03.125	1	Washer
G	03.017	1	1/4-20 locknut

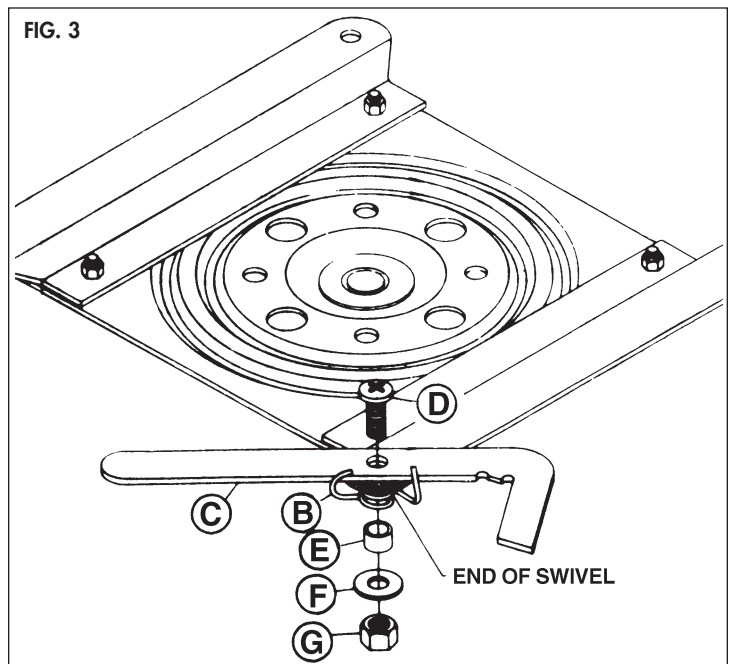
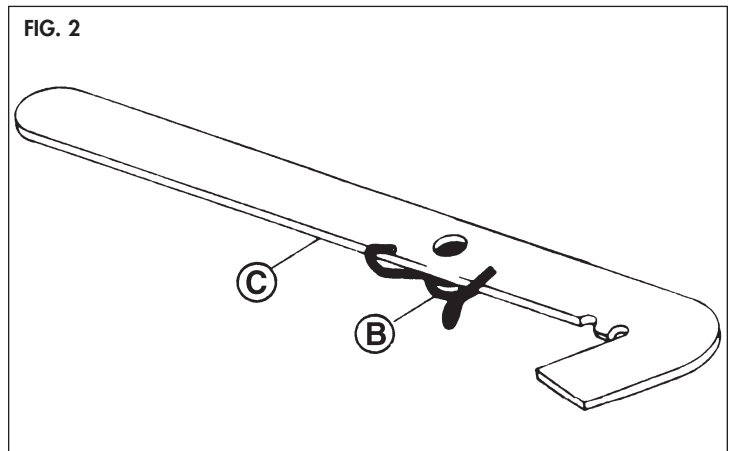
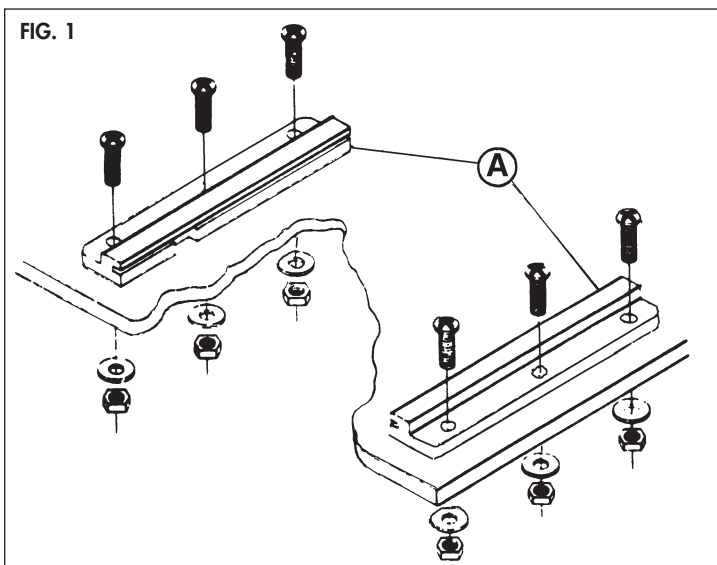

Write for
a Complete
Ezy-In Catalog

GARELICK
PO Box 8, 644 2nd Street
St. Paul Park, Minnesota 55071

Phone: 651-459-9795
E-mail: mail@garelick.com
On the Web: www.garelick.com

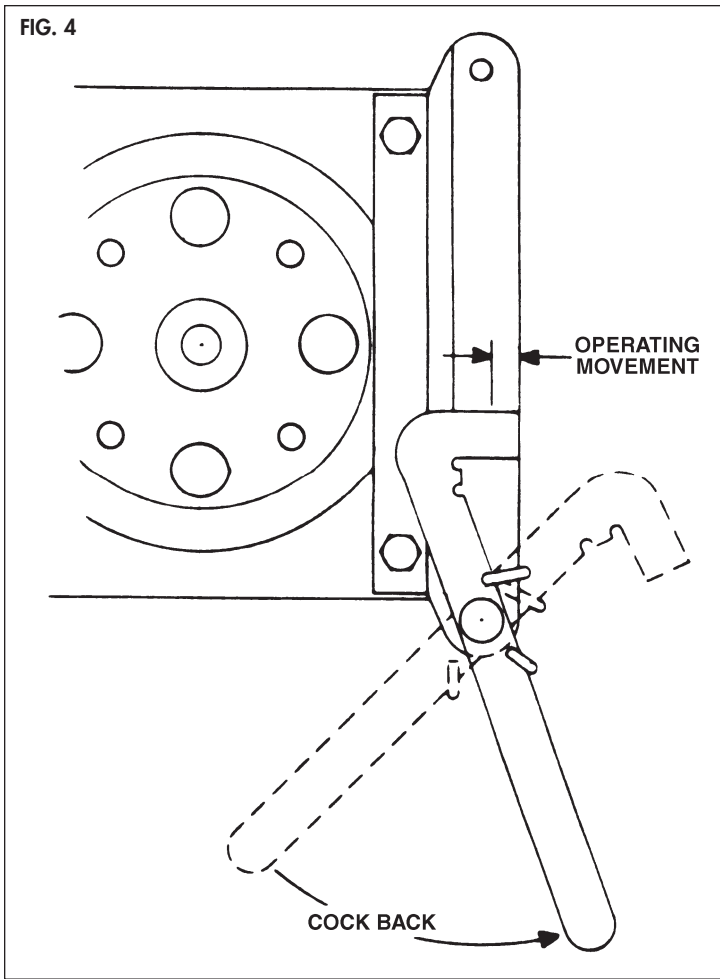

4. Cock locking handle back as illustrated in Fig. 4. Now, tighten nut (G) as shown in Fig. 3.
5. Secure swivel to seat with screws supplied on seat bottom. Use instructions given with model 75018 swivel.
6. Rotate swivel so locking handle is in the right front position and then slide swivel ends into grooves of plastic track as indicated in Fig. 5. As locking handle hook nears the slide, cock handle back to allow complete entry of swivel and then slide swivel in until handle locks in notch of track. Seat is now locked in.
7. Reverse procedure to remove seat.
8. Periodically grease swivel and slide for easy operation.

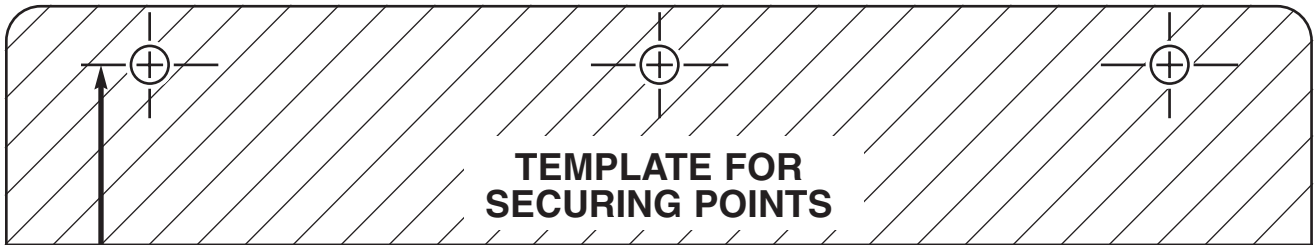
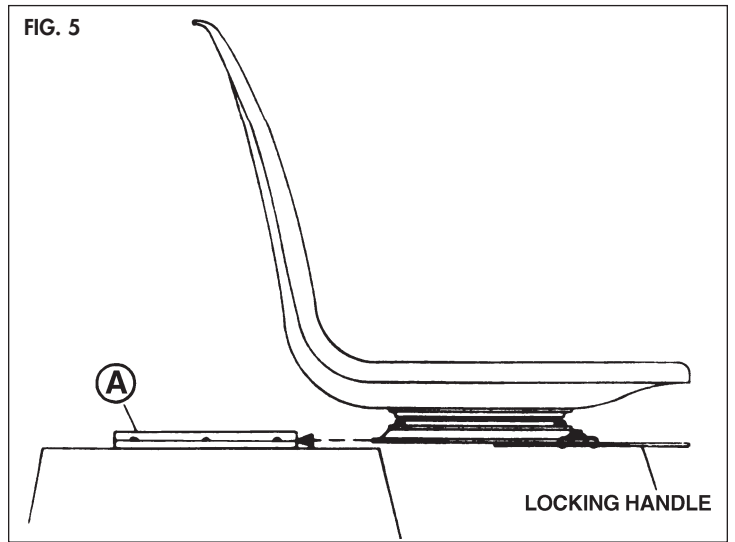

10 1/16"

