



Model 75005 Side Slide and Model 75008 Side Slide with Mounting Hardware

ASSEMBLY INFORMATION

1. Check parts against parts list.
2. Read Instructions completely before mounting.
3. **NOTE: This product uses locknuts for a secure assembly. Locknuts thread on harder than conventional nuts and require a screwdriver and wrench for attachment.**

TOOLS REQUIRED

1. Screwdriver
2. Crescent wrench adjustable to 7/16"
3. Drill

MOUNTING GUIDELINES

For best utilization of your helmsman seat, it is recommended that the seat be mounted:

- a) As high as possible to enable a clear view over the bow.
- b) As close as possible to the wheel, leaving just enough room to slide on to the seat from the side (see fig. 1).

MODEL 75005 SIDE SLIDE

1. Position slide (A) on port or starboard bulkhead of boat so it will allow seat to conform to the Mounting Guidelines given above. When positioning, it is recommended that the mounting plate be locked as far forward as possible. This will allow one to utilize the full slide travel by attaching the seat close to the wheel (see figs. 1 & 2).
2. Make certain that the slide is parallel to the deck surface and that it will be no higher above the deck than the stanchion leg's measured length (see fig. 1).
3. Mount slide to side bulkhead using all 8 holes provided and secure in position with fasteners that are suitable for boat's particular construction. NOTE: fasteners not provided.
4. Attach seat to mounting plate with appropriate hardware and fasteners (not provided). NOTE: Fig 2 shows an application of seat mounting hardware model 75055, available.
5. Attach stanchion leg (not provided) to seat bottom for proper support. NOTE: Stanchion leg included in model 75055 or singly as 75014, available.

MODEL 75008 SIDE SLIDE WITH MOUNTING HARDWARE

1. Attach the 2 U-mounting brackets (B) to the mounting plate of the slide (A) by aligning the holes in both and inserting bolts (C) through the U-brackets, mounting plate and lockwashers (D). Secure in position with nuts (E). See fig. 2.
2. Attach both support brackets (F) to U-mounting brackets (B) by positioning brackets as in fig. 2, aligning their holes and inserting bolts (G). Secure with locknuts (H). Finger tighten only. These nuts will have to be removed in step 5.

please turn to other side

Parts List for Model 75005

Ref. Letter	Factory Part No.	No. Req.	Description
A	59.500	1	Side Slide

Parts List for Model 75005

Ref. Letter	Factory Part No.	No. Req.	Description
A	59.500	1	Side Slide
B	50.109	2	U-mounting bracket
C	03.107	4	10 - 24 x 5/8" bolt
D	03.120	4	#10 lockwasher
E	03.025	4	10 - 24 x 5/8" bolt
F	59.026	2	Support Bracket
G	03.080	2	1/4 - 20 x 1-1/2" bolt
H	03.017	2	1/4 - 20 locknut
I	03.096	14	#10 x 7/8" screw
J	59.027	1	Socket casting
K	59.217	1	Stanchion leg 30"
L	10.001	1	1" White poly tip

FIG. 1

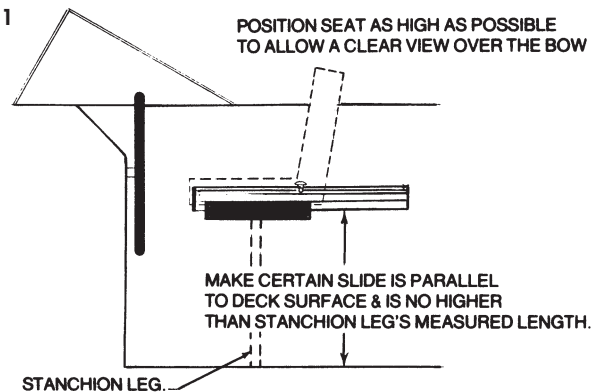
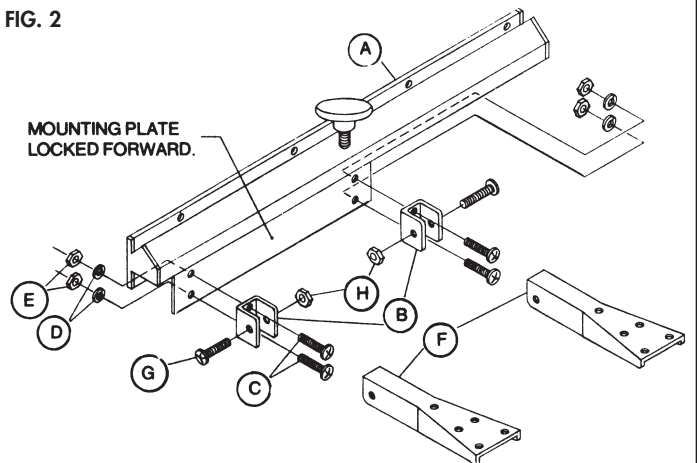

FIG. 2



Mounting Instructions – Model 75005 Side Slide and Model 75008 Side Slide with Mounting Hardware

3. After choosing the side to be mounted, refer to fig. 3 and position both support brackets on the bottom of the seat so that:
 - a) All screw holes are located on the seat bottom.
 - b) Brackets are centered on the seat bottom for maximum support.
 - c) Seat will be positioned far enough away from slide so that seat will not interfere with slide travel and folding action.
NOTE: It is allowable to mount support brackets over the hinge on the seat bottom for correct positioning.
4. Mark the bracket's hole locations on the seat bottom and drill all with a 1/8" bit.
5. Remove the two support brackets from the U-mounting brackets and align them with the drilled holes on the seat bottom. Secure them to the seat bottom using screws (I).
6. Position socket casting (J) on the seat bottom so it is centered on the seat's side and at least 1" from the edge. Make sure that the flat side of socket faces towards the mounted support brackets (see fig. 3). Mark the socket's 4 holes and drill them with a 1/8" bit. Secure the casting in position with 4 screws (I).
7. Attach slide assembly (A) to the side bulkhead of boat by following steps 1,2 & 3 for the 75005 Slide Assembly above.
8. Attach seat to slide by aligning support bracket's and U-mounting bracket's holes, inserting bolts (G) and securing with locknuts (H).
9. Insert the grooved end of stanchion leg (K) into socket casting mounted on seat. Check to see that bottom is parallel to deck surface. If not, cut off the appropriate length of tubing on opposite end with a hacksaw. Slip poly tip (L) on end of stanchion leg. NOTE: Tip will go on more easily if first heated in warm water.

