



Model 75006 Seat Slide Assembly with Swivel

Parts List for Model 75006

Ref. Letter	Factory Part No.	No. Req.	Description
A	49.045	1	Swivel
B	59.308	1	Anodized aluminum slideplate
C	03.069	4	1/4-20 x 3/4" hexhead capscrew
D	03.161	4	3/4" x 3/16" poly washer
E	03.125	4	1/4" washer
F	03.017	4	1/4-20 locknut
G	59.306	1	Anodized aluminum track w/hole
H	59.307	1	Anodized aluminum track w/nut
I		4	1/4-20 x 1" machine screw (supplied with EEz-In® seal)
J	03.119	4	1/4" s.s. lockwasher
K	03.116	4	#14 x 1" s.s. screw
L	03.128	1	s.s. 3/8" hole washer
M	03.133	1	1" poly washer
N	59.064	1	s.s. locking rod

s.s. means stainless steel

ASSEMBLY INFORMATION

1. Check parts against parts list.
2. Read instructions completely before starting assembly.
3. **NOTE: This product uses locknuts for a secure assembly. Locknuts thread on harder than conventional nuts and require a screwdriver and wrench for attachment.**

TOOLS REQUIRED

1. Screwdriver
2. Drill
3. Wrench adjustable to 7/16"

ASSEMBLY INSTRUCTIONS

1. Take swivel (A), rotate its top and bottom halves so slotted holes on bottom plate are exposed (fig. 1) and mark their position at desired mounting location on boat.
2. Align slotted holes of both swivel (A) and slideplate (B). Refer to fig. 1 and insert screw (C) through slideplate (B), polywasher (D), washer (E), swivel (A) and secure with locknut (F). Repeat step 2 for the three other slotted holes.
3. Determine in which direction slide travel is desired (see fig. 2) and then position aluminum tracks (G & H) on seat bottom as illustrated in fig. 3. **NOTE:** Decide which side of seat locking rod (N) is desired and then place aluminum track (G) on that side of seat bottom.
4. Attach both tracks (G & H) to seat bottom by aligning the four slotted holes #1 in tracks and the four machine-threaded T-nut insert holes in seat bottom. Insert four 1/4-20 x 1" machine screws (I) (provided with EEz-In® seats) and use lockwashers (J). Screw them loosely into holes.
5. Grease the grooves of aluminum tracks (G & H) and the open sides of slideplate (B).

please turn to other side

FIG. 1

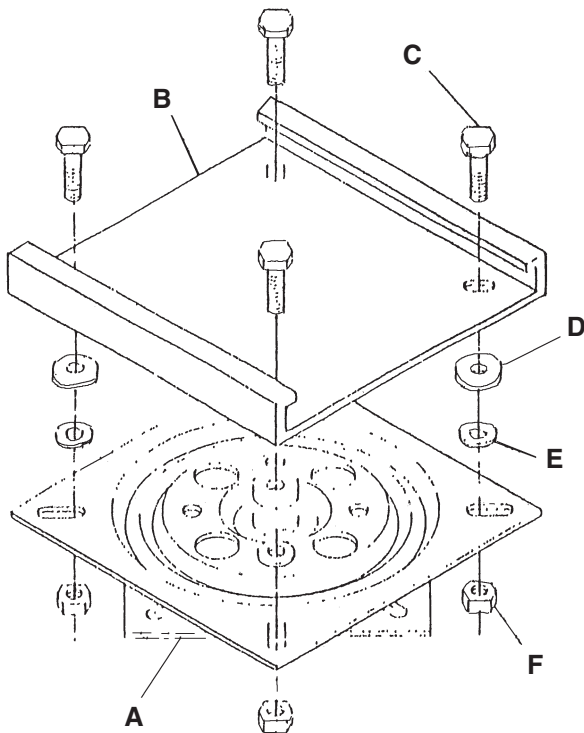
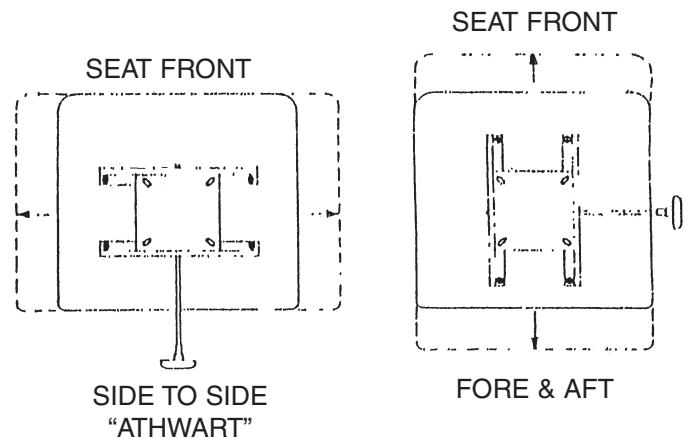

FIG. 2



Assembly Instructions – Model 75006 Seat Slide Assembly with Swivel

6. Slip slideplate (B) with attached swivel into grooves of aluminum tracks as illustrated in fig. 3. Make certain that the open ends of the slideplate touch the endwalls of the grooves and that plate has free travel in both directions. When this is achieved, tighten the four 1/4-20 x 1" machine screws.
7. Secure slide assembly to seat bottom by drilling four 3/16" holes in seat bottom at holes #2 in aluminum tracks (see fig. 3). Fasten tracks in position by using four screws (K).
8. Slide out slideplate assembly (B) from tracks and then mount it to boat by drilling the four marked holes from step 1. Secure with appropriate fasteners best suited for your particular application.
9. Slide seat with mounted tracks onto mounted slideplate as illustrated in fig. 3. Center slideplate in tracks. Slip s.s. washer (L) and then polywasher (M) over locking rod (N). Slide rod into hole of track (G) and thread rod into nut of track (H) (see fig. 3).
10. Periodically lubricate slide, track and swivel for easy operation.

FIG. 3

