



Mounting and Operating Instructions for Heavy Duty Outboard Motor Bracket Models 71090 and 71091

Form 12.295

OUTBOARD MOTOR BRACKET MOUNTING INSTRUCTIONS

IMPORTANT INSTRUCTIONS

Check hardware pack contents for the following mounting hardware:

- 4 - 5/16 x 3" stainless steel carriage bolts
- 4 - 5/16" stainless steel locknuts

1. Read instructions completely before starting assembly.
2. Motor bracket must remain in "UP" position throughout installation.
3. DO NOT operate motor bracket unless motor is installed on bracket and is attached to the boat.
4. This bracket is under spring tension. Exercise extreme caution when adjusting and installing.

MOUNTING INSTRUCTIONS

Refer to Fig. 1

Measure the distance on your outboard motor between the cavitation plate and the upper inside edge of the mounting clamp. Subtract 2" from this length. Then add the total travel distance of your model outboard motor bracket from the table below to the distance measured on your motor.

FIG. 1

INSIDE OF TOP OF CLAMP

MEASURE THIS DISTANCE

CAVITATION PLATE

MODEL	H.P. RATING	MOTOR WEIGHT NOT TO EXCEED	VERTICAL TRAVEL
71090	7½ TO 30	169 LBS.	9½"
71091	7½ TO 25	175 LBS.	15½"

NOTE: Vertical travel is based on installation that is perpendicular to waterline.

Refer to Fig. 2

Mark this total length on a stick and tape it so that the top is flush with the top of the mounting board of the motor bracket. Choose the most appropriate side of your transom for mounting the bracket. Position your bracket so it will not interfere with the turning operation of your main motor or rudder.

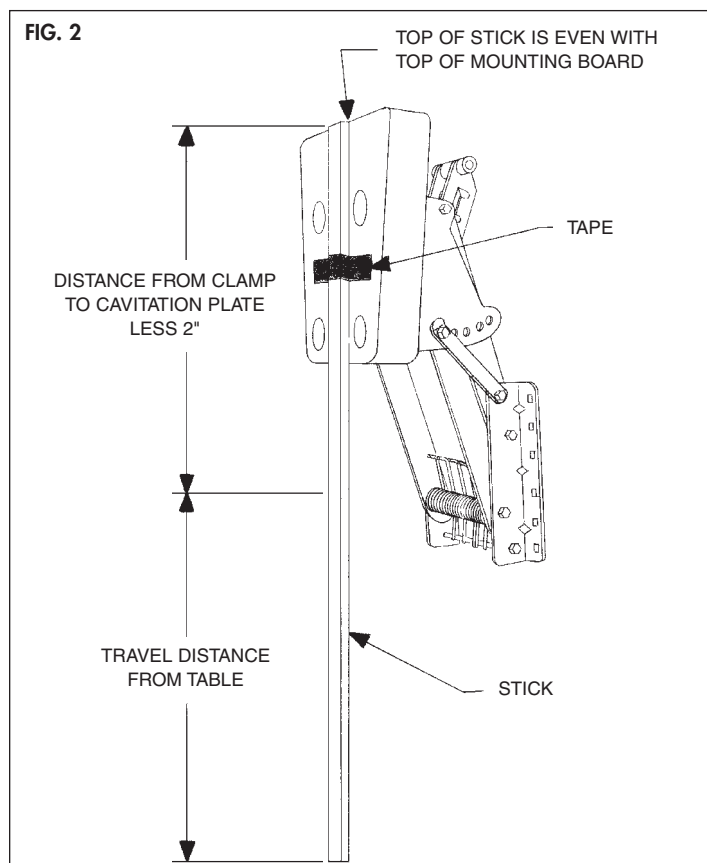

Refer to Fig. 3

For Powerboat Installation: Take your outboard motor bracket with the stick taped on and place the mounting flanges on your transom. Position the bracket so the bottom of the stick is one inch above the boat's bottom at the centerline of the outboard motor bracket.

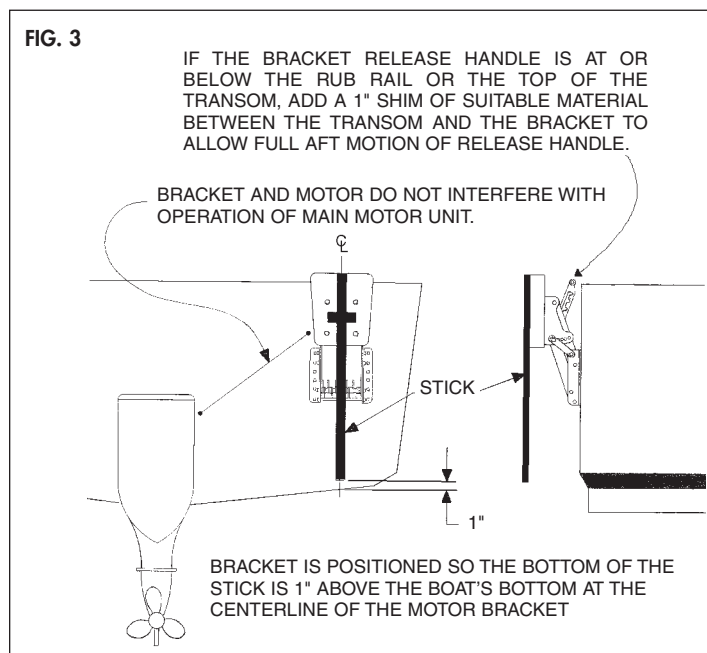

(over)

Mounting and Operating Instructions – Heavy Duty Outboard Motor Bracket Models 71090 and 71091

Refer to Fig. 4

For Sailboat Installation: Take your outboard motor bracket with the stick taped on and place the mounting flanges on your transom. Position the bracket so the bottom of the stick is even with the boat's actual waterline.

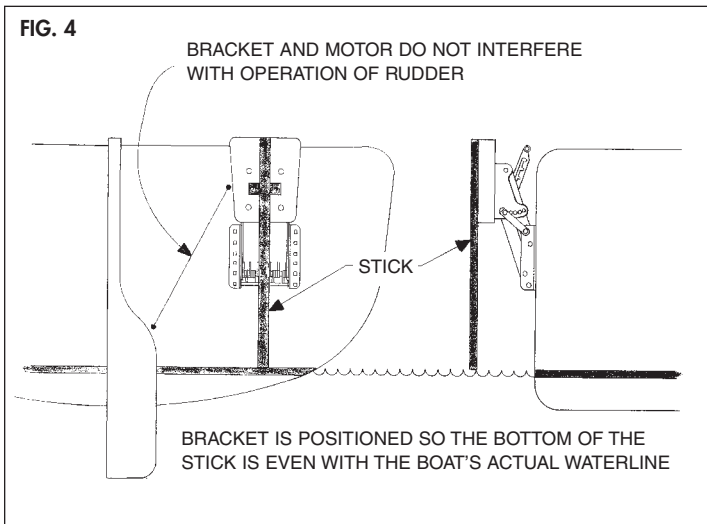

Refer to Fig. 5

After the bracket has been properly positioned, mark the four outside hole locations using the bracket as a template on your transom (See Fig. 5). **NOTE:** If it is necessary to use the center holes on the bracket, you must reverse the mounting bolts so their heads will be on the inside of the transom. Drill the four marked 3/8" holes, making sure to hold the drill at right angles to the transom when drilling.

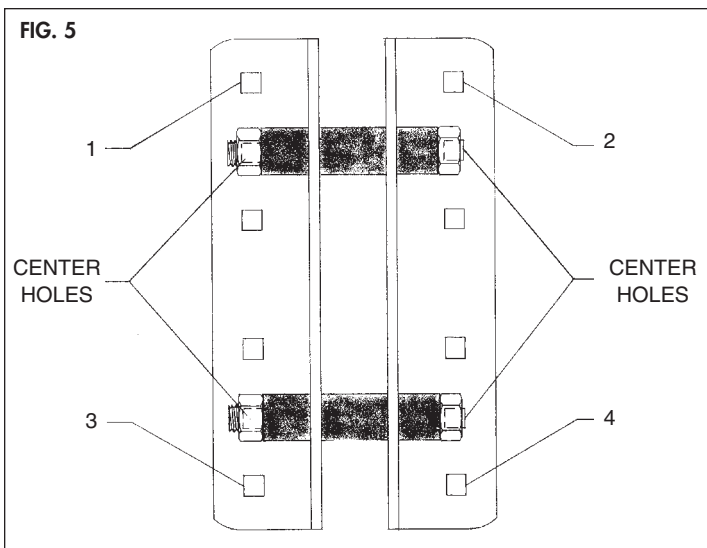

Refer to Fig. 6

Check the angle of the transom on your boat and determine if the motor to be used can be trimmed so the cavitation plate is parallel to the waterline. If not make a wedge out of suitable material to do so.

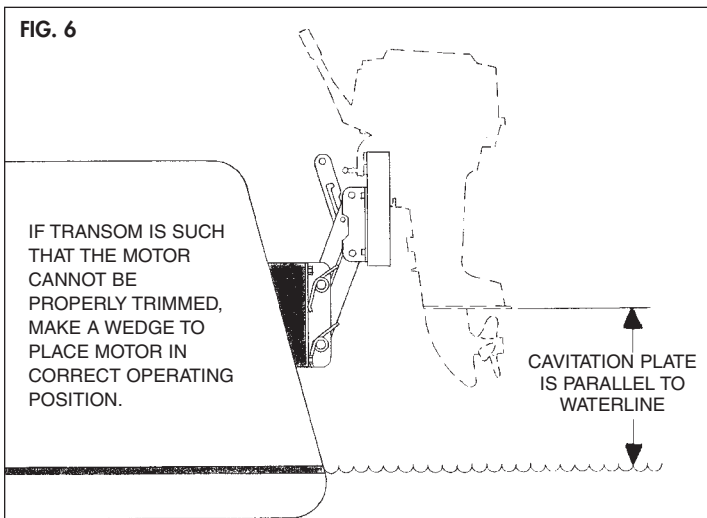

Refer to Fig. 7

It is recommended that a backing plate be made and mounted on the inside of the transom for needed rigidity. Attach your motor bracket to the transom by coating the inside surfaces of the mounting flanges and backing plate with a marine adhesive/sealant compound and then squeeze a small amount into each bolt hole on both sides of the transom. Secure the bracket to the transom with the supplied hardware as illustrated. The bracket is now ready for motor mounting.

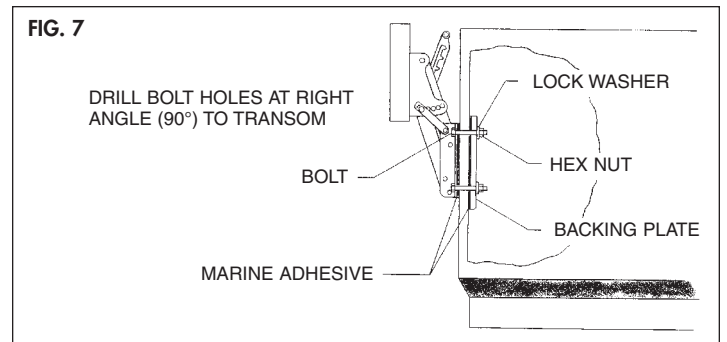

OPERATING INSTRUCTIONS

Refer to Fig. 8

To Lower Motor: Loosen safety lock by counter rotating red knobs. Rotate right knob toward boat; left knob away from boat. Pull lever handle toward boat to disengage lock pin. Push down through length of handle to adjust to desired height. Tighten safety lock by counter rotating red knobs. Rotate right knob away from boat. Rotate left knob toward boat.

To Raise Motor: Loosen safety lock. Pull lever handle toward boat and lift to desired height. Tighten safety lock.

NOTE: Always tighten safety lock after adjusting bracket height.

NOTE: The bracket springs counter most of the motor's weight; however, a push or lift through the length of the handle may be needed.

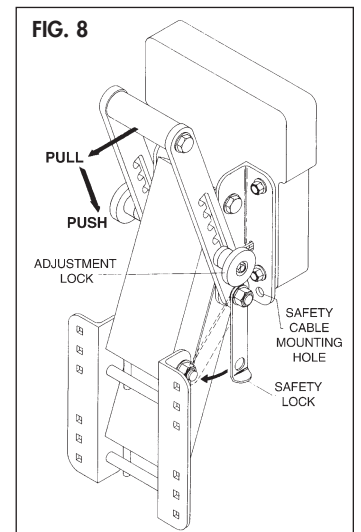

AUXILIARY OUTBOARD MOTOR BRACKET IMPORTANT CAUTION GUIDELINES

Failure to observe these points could result in personal injury or damage to Bracket, Motor or Boat.

1. Install motor bracket only in "up" position with safety lock in "locked" position.
2. Always remove your motor from the bracket when trailering. Failure to do so could result in damage to boat, motor and bracket.
3. Do not exceed the stated H.P. rating or weight.
4. Make sure the motor clamps are tight before use.
5. Use a safety cable when operating your motor.
6. Operate motor at low speed.
7. Avoid turning motor at full throttle, refrain from sharp turns.
8. Do Not raise or lower bracket when motor is running.
9. Operate motor in lowest position possible for best performance.
10. Always raise motor when not in use. It may be necessary to turn motor prior to tilting to avoid interference.
11. Avoid contact with moving parts.
12. Keep pivoting bolts greased to insure smooth operation.