



Mounting and Operating Instructions for Outboard Motor Bracket Models 71040, 71041, 71057, 71042, 71044, and Outboard Motor Bracket Adapter Plate Model 71053

OUTBOARD MOTOR BRACKET MOUNTING INSTRUCTIONS

(See reverse side for Adapter Plate Installation Instructions)

IMPORTANT INSTRUCTIONS

Check hardware pack contents for the following mounting hardware:

- 4 - 5/16 x 3" stainless steel carriage bolts
- 4 - 5/16" stainless steel locknuts

1. These brackets are not recommended for use with 9.9 4-stroke motors.
2. Read instructions completely before starting assembly.
3. Motor bracket must remain in "UP" position throughout installation.
4. DO NOT operate motor bracket unless motor is installed on bracket.

MOUNTING INSTRUCTIONS

Refer to Fig. 1

Measure the distance on your outboard motor between the cavitation plate and the upper inside edge of the mounting clamp. Subtract 2" from this length. Then add the total travel distance of your model outboard motor bracket from the table below to the distance measured on your motor.

FIG. 1

INSIDE OF TOP OF CLAMP

MEASURE THIS DISTANCE

CAVITATION PLATE

MODEL	H.P. RATING	MOTOR WEIGHT NOT TO EXCEED	VERTICAL TRAVEL
71040	TO 8	59 LBS.	8½"
71041	OVER 7½ TO 20	115 LBS.	11¼"
71042	OVER 7½ TO 12	82 LBS.	14¼"
71044	TO 30	135 LBS.	14¼"

Refer to Fig. 2

Mark this total length on a stick and tape it so that the top is flush with the top of the mounting board of the motor bracket. Choose the most appropriate side of your transom for mounting the bracket. Position your bracket so it will not interfere with the turning operation of your main motor or rudder.

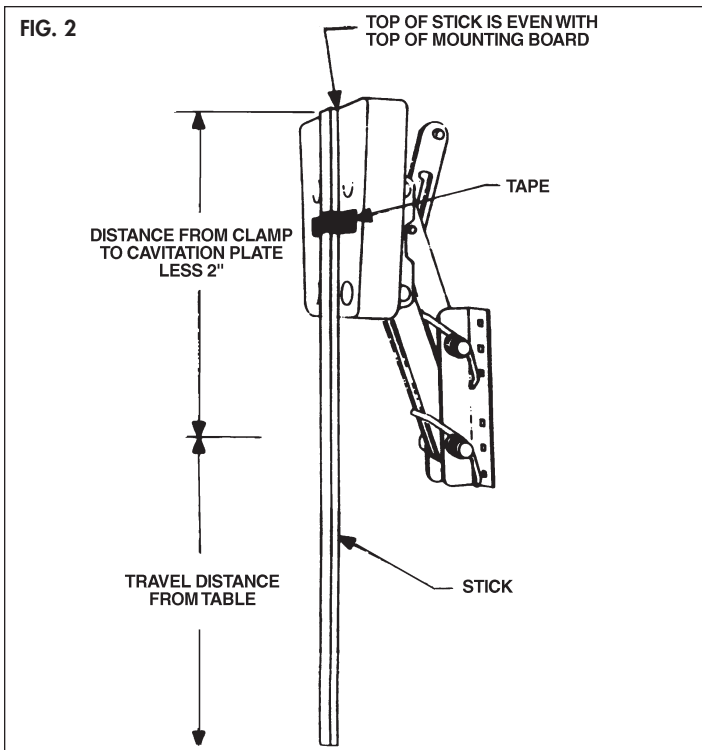

Refer to Fig. 3

For Powerboat Installation: Take your outboard motor bracket with the stick taped on and place the mounting flanges on your transom. Position the bracket so the bottom of the stick is one inch above the boat's bottom at the centerline of the outboard motor bracket.

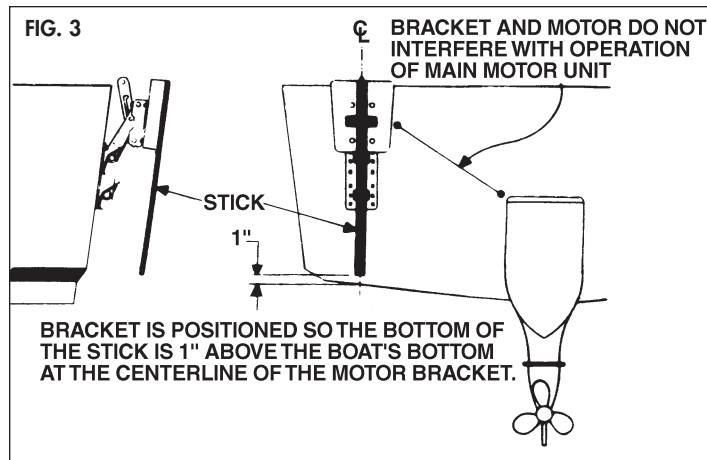

Refer to Fig. 4

For Sailboat Installation: Take your outboard motor bracket with the stick taped on and place the mounting flanges on your transom. Position the bracket so the bottom of the stick is even with the boat's actual waterline.

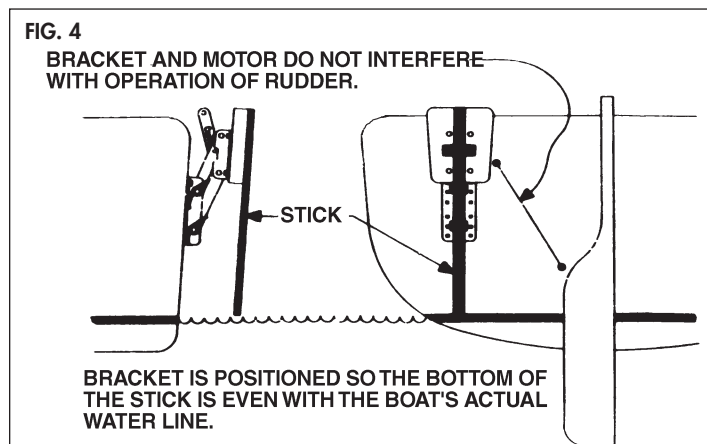

(over)

Refer to Fig. 5

After the bracket has been properly positioned, mark the four outside hole locations using the bracket as a template on your transom (See Fig. 5). **NOTE:** If it is necessary to use the center holes on the bracket, you must reverse the mounting bolts so their heads will be on the inside of the transom. Drill the four marked 3/8" holes, making sure to hold the drill at right angles to the transom when drilling.

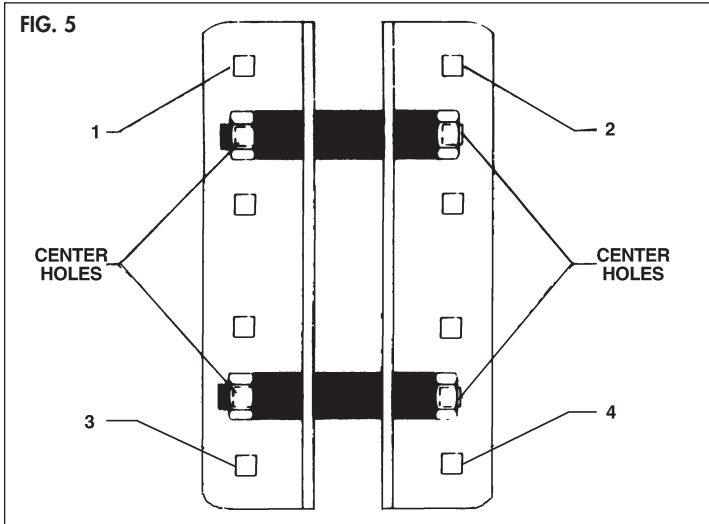

Refer to Fig. 6

Check the angle of the transom on your boat and determine if the motor to be used can be trimmed so the cavitation plate is parallel to the waterline. If not make a wedge out of suitable material to do so or, use an EEZ-IN Adjustable Angle Bracket Model 71045.

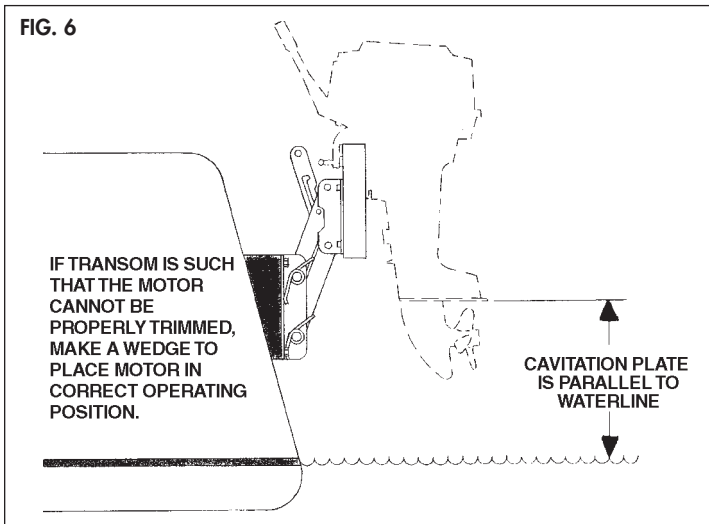

Refer to Fig. 7

If your transom is less than 2" thick, it is recommended that a backing plate be made and mounted on the inside of the transom for needed rigidity. Attach your motor bracket to the transom by coating the inside surfaces of the mounting flanges and backing plate with a marine adhesive/sealant compound and then squeeze a small amount into each bolt hole on both sides of the transom. Secure the bracket to the transom with the supplied hardware as illustrated. The bracket is now ready for motor mounting.

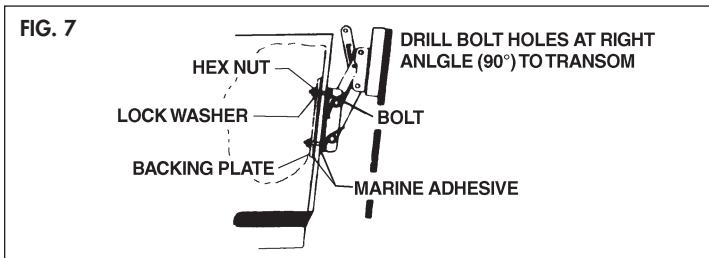

OPERATING INSTRUCTIONS

To move bracket bear down on motor, release locking lever by pushing Handle towards the mounting board, allowing the guide pin to slide in its safety groove. Bracket will snap locked when fully extended in its "up" or "down" position. The bracket springs counter most of the motor weight; however, a slight push or lift is necessary to equalize this. **ALWAYS LOWER MOTOR SLOWLY.** All four arm bolts on the bracket should be tight, but not too much to prevent desirable up and down action.

**AUXILIARY OUTBOARD MOTOR BRACKET
IMPORTANT CAUTION GUIDELINES**

1. Install motor bracket only in "up" position.
2. Always remove your motor from the bracket when trailering. Failure to do so could result in damage to boat, motor and bracket.
3. Do not exceed the stated H.P. rating or weight.
4. Use a safety cable when operating your motor.
5. Operate motor at low speed.
6. Avoid turning motor at full throttle, refrain from sharp turns.
7. Operate motor in lowest position possible for best performance.
8. Always raise and tilt motor when not in use.
9. Keep pivoting bolts greased to insure smooth operation.

IMPORTANT RECOMMENDATIONS

A grease coating on all bolts and nuts will further increase resistance to corrosion. Keep pivoting points lubricated. Remove your motor from the bracket when trailering your boat. Use a safety cable when operating your motor. Keep wood block sealed and varnished to increase longevity.

MODEL 71053 ADAPTER PLATE MOUNTING INSTRUCTIONS

1. Check hardware packet for the following mounting hardware:
 - 4 - 5/16 x 3" stainless steel carriage bolts
 - 4 - 5/16" stainless steel lockwashers
 - 4 - 5/16" stainless steel hexnuts
 Prior to installation, be certain to read instructions completely.
2. Slide motor bracket into adapter plate as illustrated in Fig. 8 and secure it in position by turning locking handle as indicated in Fig. 8.
3. Follow mounting instructions for Outboard Motor Bracket on the reverse side to correctly Position unit. **NOTE:** Disregard bracket's hardware packet and use supplied packet with adapter plate. For mounting use the adapter's holes as a template.

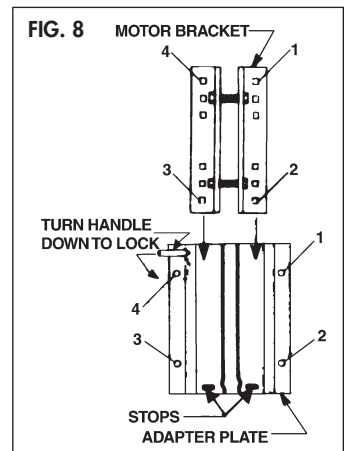

INSTALLATION INSTRUCTIONS FOR A MOUNTED MOTOR BRACKET

If your adapter plate is to be used with a mounted outboard motor bracket, remove your bracket from the boat and seal the existing holes with plugs and a marine adhesive/sealant. Position the plate on the transom so the bracket will be in the same position as before. Follow Steps 5-7 for the Outboard Motor Bracket to secure the plate in place.