

Copyright 2006 Teleflex Incorporated (USA)

INSTALLER: THESE INSTRUCTIONS CONTAIN IMPORTANT SAFETY INFORMATION AND MUST BE FORWARDED TO THE BOAT OWNER.

THESE INSTRUCTIONS DESCRIBE HOW TO INSTALL THE CH2200ENC SERIES SIDE MOUNT CONTROL.

ADDITIONAL EQUIPMENT REQUIRED:

One Cable - P/Ns CC172XX and CC633XX (CC172 is a 3300-type cable used for shift in all applications.)

Note: This control does NOT provide "Start in Gear" protection, which must be provided by the engine manufacturer.

⚠ WARNING

READ THESE INSTRUCTIONS THOROUGHLY BEFORE STARTING INSTALLATION. FAILURE TO FOLLOW THESE INSTRUCTIONS AS WELL AS THE INSTRUCTIONS PROVIDED BY THE ENGINE MANUFACTURER MAY RESULT IN LOSS OF ENGINE CONTROL WITH SUBSEQUENT PROPERTY DAMAGE AND PERSONAL INJURY. DO NOT SUBSTITUTE PARTS FROM OTHER CONTROL MAKERS, AS THEY MAY CAUSE A SAFETY HAZARD FOR WHICH TELEFLEX, INC. CANNOT ACCEPT RESPONSIBILITY.

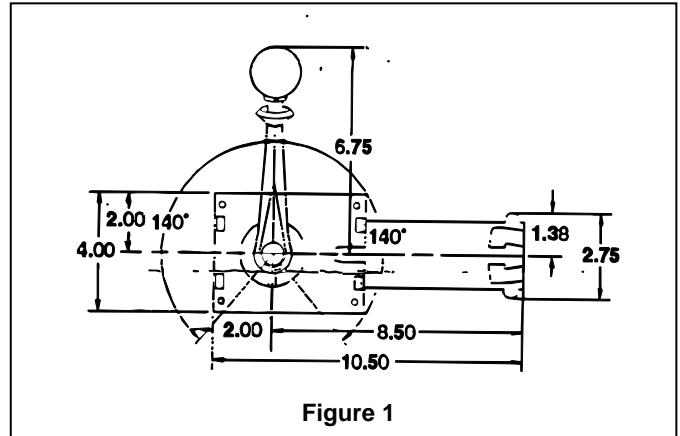

Figure 1

3. CONNECTION OF THE SHIFT CABLE

NOTE: ALWAYS CONNECT THE CABLE TO THE MECHANISM BEFORE CONNECTING IT TO THE ENGINE AND GEAR.

1. Push the shift cable through the appropriate retainer, making sure the cable seats securely into the retainer (Figure 3, item A).
2. Thread the pivot (Figure 2, item A) onto the cable terminal until the threaded portion of the terminal protrudes 5/32" (5 threads). Secure the pivot by tightening the nut (Figure 2, item B).
3. Connect the pivot to the shifting lever (Figure 3, item B) and secure with a cotter pin (Figure 3, item C).

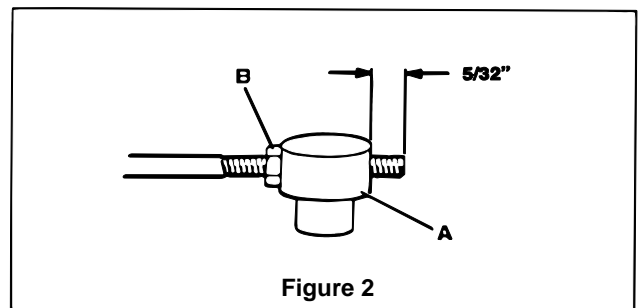

Figure 2

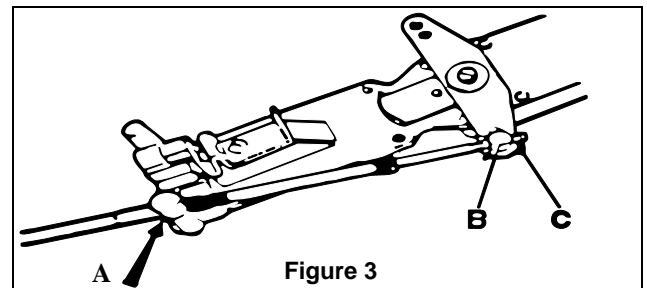

Figure 3

PREPARATION FOR MOUNTING CONTROL

1. Select a location for the control ensuring that the handle does not interfere with dashboard, steering wheel, seat, switches, or other equipment at any point in its travel. NOTE: THICKNESS OF MOUNTING SURFACE MUST NOT BE GREATER THAN 1/2". Also ensure that the shift cable will have at least 36 inches of unrestricted space for movement (see INSTALLATION OF SHIFT CABLE). Refer to Figure 1 for dimensions and clearances. NOTE: CONTROL CAN BE MOUNTED HORIZONTALLY OR VERTICALLY TO FACILITATE CABLE CLEARANCE.
2. Cut mounting holes in selected location, using template provided.
3. If not already routed, route the shift cable and engine harness to the cutout, allowing the cable and harness to protrude from the cutout enough to allow connection to the control mechanism.

INSTALLATION OF SHIFT CABLE

1. BEND RADIUS

Minimum bend radius is 8". If installed with sharper bends, cable wear will increase rapidly.

2. SUPPORTING THE CABLE

DO NOT TIE OR CLAMP THE CABLE WITHIN 36 INCHES OF THE CONTROL. WHEN SUPPORTING THE CABLE BEYOND 36 INCHES OF THE CONTROL, DO NOT TIE OR CLAMP TIGHTLY.

INSTALLATION OF WIRING HARNESS

A wire harness must be prepared for connection of the CH2200ENC control head to the engine TAC module. Every boat is different and there may be several ways to route the harness. Inside the boat there is often a channel or conduit used for wiring. This can also be used to route the wire harness for the CH2200ENC control.

When routing the wiring harness, care must be taken not to damage the cable insulation. If a harness is short, replace it with a correct length harness. Don't add a short harness to make up the required length. Run the harness over the shortest and straightest possible path. Secure the harness every 2 feet (0.6 m) with stainless steel screws and mounting head ties or clamps. Excess harness length should be neatly coiled and secured with nylon ties. The mounted harness should be as far as practical from high current wires or wiring runs and should not be subjected to water, fuel, lubricants, or excess heat.

PREPARATION OF CONTROL HEAD WIRE HARNESS

Measure from the control head mounting location along unobstructed wire runs to the engine module.

Round measurement to the next whole foot and add additional length if uncertain.

Prepare harness as shown in Figure 5 [on page 3]. It is recommended that conductors be stranded tinned copper (UL 1426 or equivalent), 18 AWG min. Colors shown are optional.

CONNECTION OF THE WIRING HARNESS

NOTE: ALWAYS CONNECT THE WIRING HARNESS TO THE CONTROL HEAD BEFORE CONNECTING TO THE ENGINE. ENGINE CONNECTION SHOULD NOT BE MADE UNTIL THE CONTROL HAS BEEN COMPLETELY INSTALLED.

Ensure that the watertight seal is in place and connect the 6-pin connector from the completed harness assembly into the rear of the potentiometer mounted on the control head mechanism. The connector should be fully seated and latched for proper operation.

THROTTLE BRAKE ADJUSTMENT

The control mechanism is equipped with an adjustable friction device (brake) for the throttle to prevent throttle creep. If needed, the friction device can be adjusted by turning the adjustment screw (Figure 4, item A) clockwise to increase braking and counterclockwise to decrease or remove braking. Any adjustments should be made with the control set at 1/2 throttle and the gear engaged. Gear shifting is not influenced by the brake.

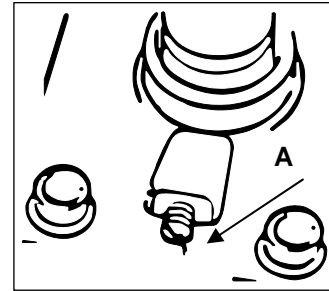
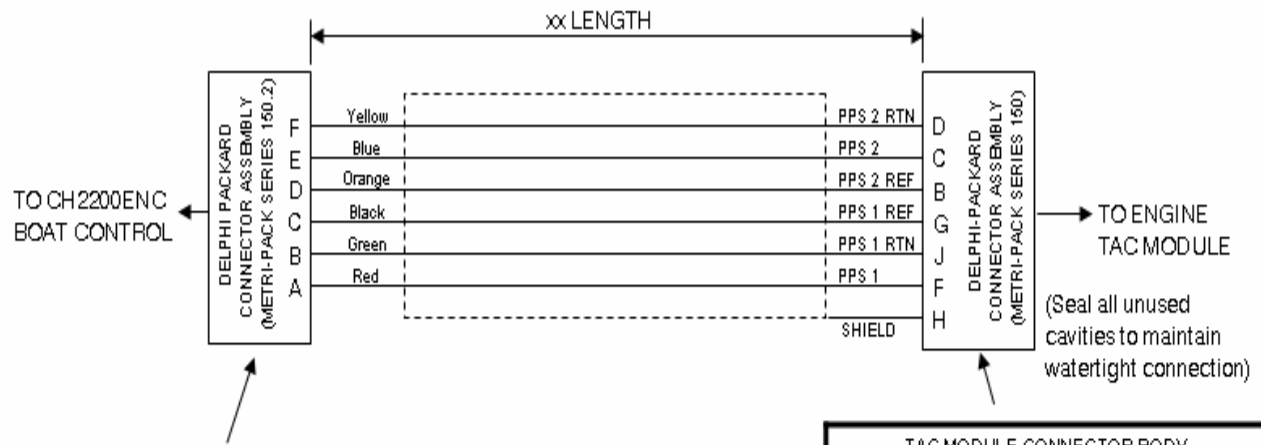

Figure 4

INSTALLATION OF CONTROL

A. INSTALLING THE MECHANISM

1. Make sure the control is in gear and at the half throttle position. This will allow the control to fit in the cutout shown in the template. If not already in half throttle position, use the handle to move in gear and at half throttle position by temporarily placing the handle on the splined shaft of the control. Push the mechanism until it seats flush against the mounting surface of the boat.
2. Secure the control mechanism to the boat with the four screws provided.



BOAT CONTROL CONNECTOR BODY (Cable seal included)	
CABLE O.D. (mm)	DELPHI PACKARD P/N
2.66 – 2.00	12162210
2.15 – 1.65	12162260
1.85 – 1.47	12162261

BOAT CONTROL FEMALE TERMINALS	
CABLE RANGE (mm ²)	DELPHI PACKARD P/N
1.0 – 0.80	12124075
0.50 – 0.35	12124076

Delphi Packard Website: www.delphiconnect.com

TAC MODULE CONNECTOR BODY	
DESCRIPTION	DELPHI PACKARD P/N
10 POSITION HOUSING	12065425
TERMINAL POSITION ASSURANCE (TPA)	12124264

TAC MODULE FEMALE TERMINALS	
CABLE RANGE (mm ²)	DELPHI PACKARD P/N
1.0 – 0.80	12048074
0.50 – 0.35	12084200

TAC MODULE CABLE SEAL	
CABLE O.D. (mm)	DELPHI PACKARD P/N
2.85 – 2.03	12048086
2.15 1.60	12089678
1.70 – 1.29	12048087
1.009 – 0.995	12084193

TAC MODULE CAVITY PLUG	
DESCRIPTION	DELPHI PACKARD P/N
CAVITY PLUG	12059168

PREPARATION OF CONTROL HEAD WIRE HARNESS

Figure 5

B. INSTALLING THE COVER (IF SUPPLIED)

1. Place the cover over the shaft and spline and snap into place on the control mechanism.

C. INSTALLING THE HANDLE

Once the mechanism has been securely mounted, the handle assembly may be attached to the control. The handle assembly contains two (2) sets of internal splines; one (1) on the chrome locking ring, and one (1) on the black handle. There are two (2) sets of mating external splines on the mechanism; one (1) on the cast housing and one (1) on the steel shaft. Each set of splines contains forty-eight (48) teeth and both sets of the 1 3/8" splines and 3/4" splines are consistently oriented to the other (See Figure 6).

1. Make sure the pinned rocker in the handle is situated in the slot in the locking ring; this is referred to as the locked position.
2. Firmly install the handle assembly onto the control so that both sets of splines are fully engaged and the steel shaft 'bottoms-out' against the internal shoulder of the handle. Since the splines on the shaft and handle will engage before the splines on the locking plate and diecast housing, make sure the locking ring rests securely on the 1 3/8" splines and cannot rotate.
3. While applying pressure firmly against the assembly and leaving the handle in the locked position, install the set screw into the bottom of the handle and tighten.
4. Once the handle has been attached with the set screw, insert the black button onto the push pin in the shaft and press firmly. Insert the #6-32 x 7/8" long machine screw through the center of the button and tighten until the screw is flush with the button. Overtightening can result in damaging the button and/or screw.

IMPORTANT: ONCE THE ASSEMBLY HAS BEEN FULLY ATTACHED AND THE ENGINE TURNED OFF, LIFT THE 'UMBRELLA' OF THE HANDLE AND CYCLE THE HANDLE THROUGH FULL FORWARD AND FULL REVERSE TO ENSURE THAT BOTH SETS OF SPLINES ARE FULLY ENGAGED. IF THE LOCKING PLATE IS CAPABLE OF ROTATING WITH THE HANDLE, REMOVE THE HANDLE ASSEMBLY AND REPEAT THE HANDLE INSTALLATION PROCEDURE. ALSO, CYCLE THE CONTROL USING THE PUSH BUTTON/NEUTRAL WARM-UP TO ENSURE THAT THE BLACK BUTTON HAS BEEN PROPERLY INSTALLED.

NOTE: Since the sets of splines are oriented and have the same number of teeth, the control allows for the handle assembly to be indexed every 7.5°. The centerline of the handle is aligned with the centerline of the control, so if the control is mounted horizontally, the handle can be attached perpendicularly to the control.

CONNECTION OF WIRING HARNESS AND SHIFT CABLE CABLES TO ENGINE

1. Read engine maker's manual and use the recommended attachment kits to connect shift cable to the engine.
2. Connect the 10-pin connector from the wiring harness into the engine TAC module. The watertight seal should be in place and connector should be fully seated and latched for proper operation.

MAINTENANCE

Although very little maintenance is required for this control system, periodically check the following:

1. Ensure that the control is firmly mounted.
2. If the handle develops lost motion, check that it is firmly attached the control body, that the control body is firmly attached to the boat and that the cables are firmly attached to the control, engine, and gear.
3. If stiffness of operation develops, disconnect cable from the engine and check operation. If stiffness is due to shift cable, it must be replaced.

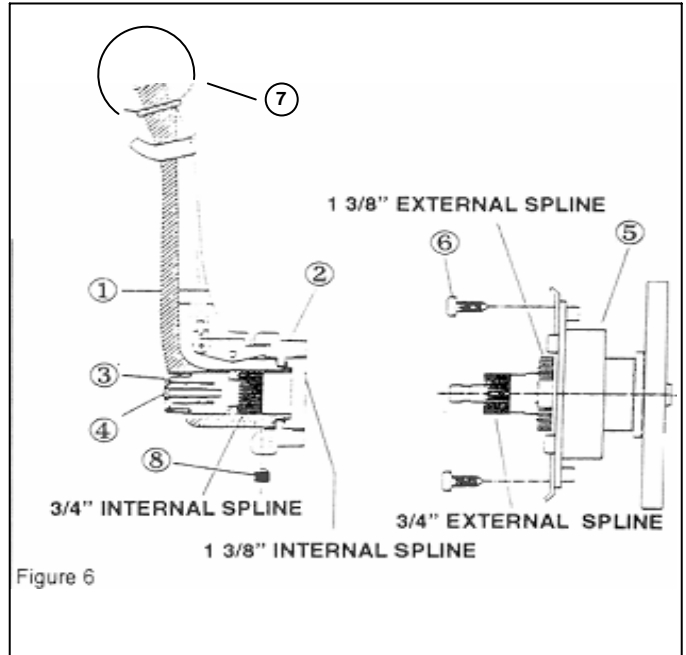

Figure 6

PARTS LIST

ITEM	DESCRIPTION	QUANTITY
1	Handle	1
2	Locking Ring	1
3	Neutral Detent Warm-up Button	1
4	Button Mounting Screw	1
5	Control Mechanism	1
6	Control Mounting Screw	4
7	Knob	1
8	Handle Mounting Set Screw	1
9*	Pivot, Small (3/16") Dia. Thread	2
10	Cotter Pin (Figure 3, Item C)	1

*See Figure 2, item A

KEEP THESE INSTRUCTIONS WITH YOUR BOAT FOR FUTURE REFERENCE.

OPERATION OF CONTROL

THROTTLE WARM-UP IN NEUTRAL POSITION

To start the boat's engine and to activate the throttle for engine warm-up, the handle must be in the neutral position. Neutral can be found by rotating the handle (by grasping the knob or stem) until the handle locks in position and can not be rotated in either direction. Usually the handle is vertical as shown in Figure 7 when in the neutral position.

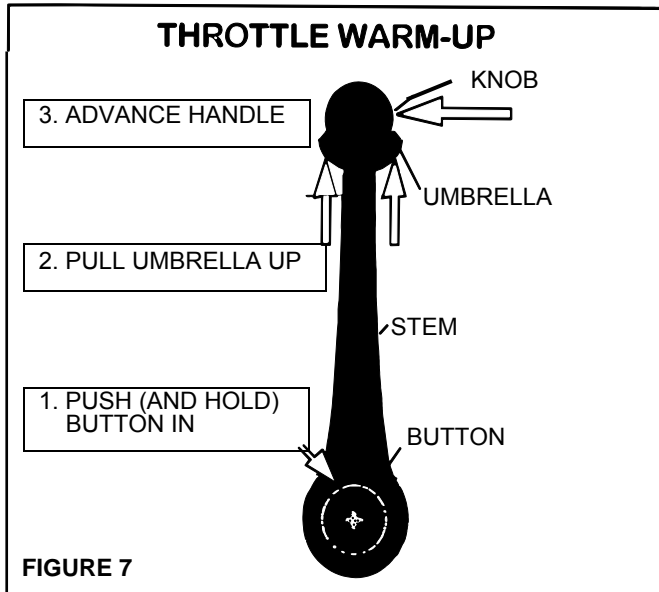

Push in the button with your left hand while grasping the umbrella and knob with your right hand and pull the umbrella up toward the knob (see Figure 7). While still holding the button and umbrella, advance the handle forward to put the control in warm-up throttle mode. Once in this mode, the button and umbrella can be released and throttle can be adjusted by simply moving the control handle away from the neutral position to increase throttle and towards the neutral position to decrease throttle. Returning the handle to the neutral position will disengage throttle warm-up.

SHIFTING THE CONTROL

To shift the control into forward or reverse, pull the umbrella up toward the knob and advance the handle forward (for forward travel) or rearward (for reverse travel) until the handle settles into a detent at approximately 30° of travel (see Figure 8). At this point, the control has engaged the gear and automatically entered the throttle mode where further advancement of the handle will increase the throttle. Once in the throttle mode, it is no longer necessary to pull on the umbrella. Increase or decrease throttle by simply moving the handle.

