

INSTRUCTION SHEET Mercarb Two-Barrel

General Exploded View

The general design and parts shown will vary to individual units covered on this instruction sheet.

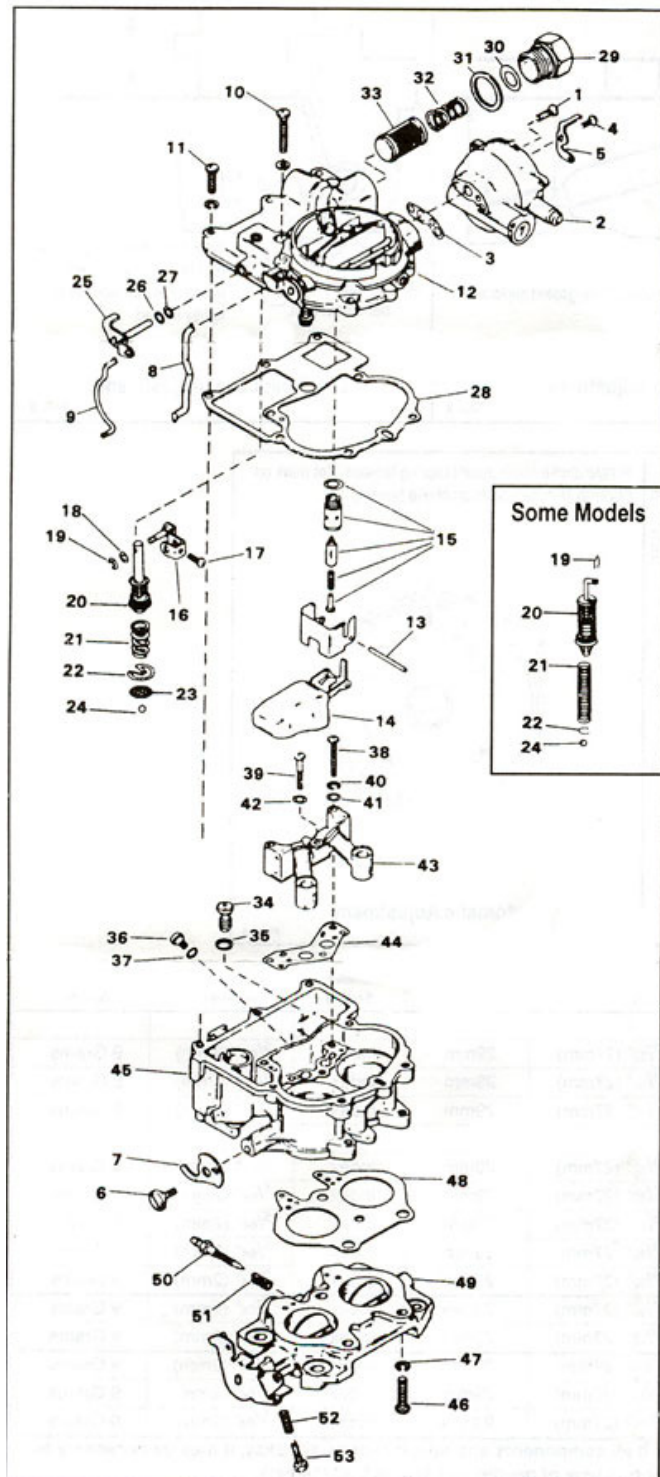

Disassembly

Use the exploded view as a guide. The numerical sequence may generally be followed to disassemble unit far enough to permit cleaning and inspection.

Nomenclature

Ref.No.	Ref.No.
1. Screw, Choke Housing	28. Gasket, Bowl Cover
2. Choke Housing Assembly	29. Fitting, Fuel Inlet
3. Gasket, Choke Housing	30. Gasket, Fuel Inlet
4. Screw, Choke Lever	31. Gasket, Fuel Inlet
5. Lever	32. Spring, Fuel Filter
6. Screw, Fast Idle Cam	33. Filter
7. Fast Idle Cam	34. Power Valve Assembly
8. Choke Rod	35. Gasket, Power Valve
9. Pump Rod	36. Jet
10. Screw, Bowl Cover (Long)	37. Gasket, Jet
11. Screw, Bowl Cover (Short)	38. Screw, Venturi Assembly
12. Bowl Cover Assembly	39. Screw, Venturi Center
13. Pin, Float	40. Lockwasher
14. Float	41. Gasket
15. Needle & Seat Assembly	42. Gasket
16. Pump Shaft & Lever Assembly	43. Venturi Cluster
17. Screw, Pump Shaft Assembly	44. Gasket, Venturi Cluster
18. Washer, Pump Shaft	45. Flat Bowl Assembly
19. Retainer, Pump Shaft	46. Screw, Throttle Body
20. Accelerator Pump Assembly	47. Lockwasher
21. Spring, Pump Assembly	48. Gasket, Throttle Body
22. Retainer, Spring	49. Throttle Body
23. Strainer	50. Needle, Idle Mixture Adjusting
24. Check Ball	51. Spring, Idle Mixture Screw
25. Accelerator Pump Lever	52. Screw, Idle Speed Adjusting
26. Washer, Inner	53. Spring, Idle Speed Screw
27. Washer, Outer	

Cleaning

Cleaning must be done with carburetor disassembled. Use a carburetor cleaning solvent to soak parts long enough to soften and remove all foreign material. Make certain the throttle bores are free of all carbon and varnish deposits. Rinse off in suitable solvent. Blow out all passages in castings with compressed air and check carefully to ensure thorough cleaning of obscure areas.

Reassembly

Reassemble in reverse order of disassembly. Note special instructions and follow numerical outline in making adjustments necessary for carburetor being serviced.

Special Instructions

Idle adjusting needles: Turn each needle in lightly until seated, then back out two turns. **(Do not install idle limiter caps at this time.)**

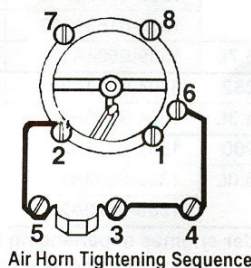

ADJUSTMENTS

See data table for measurements

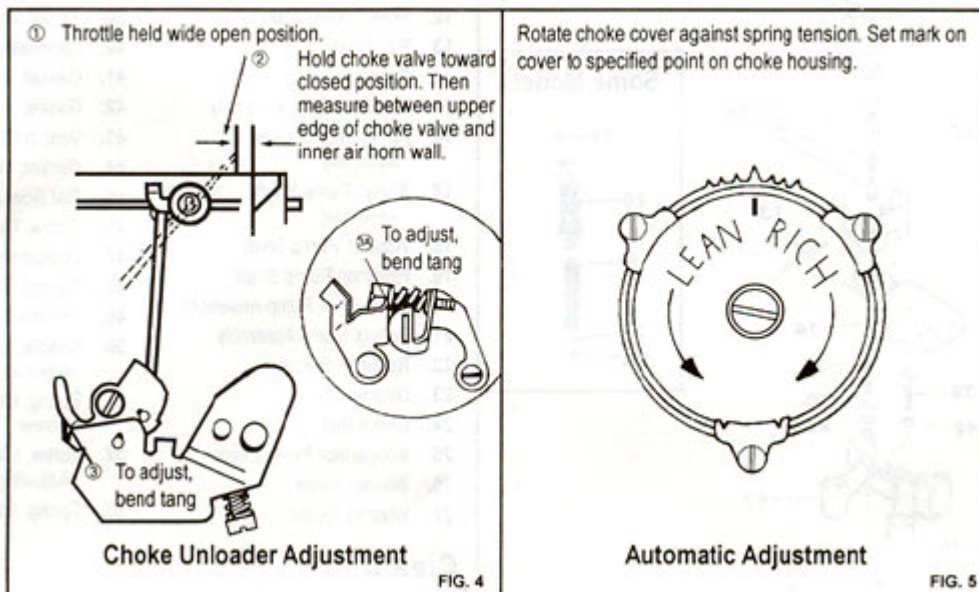
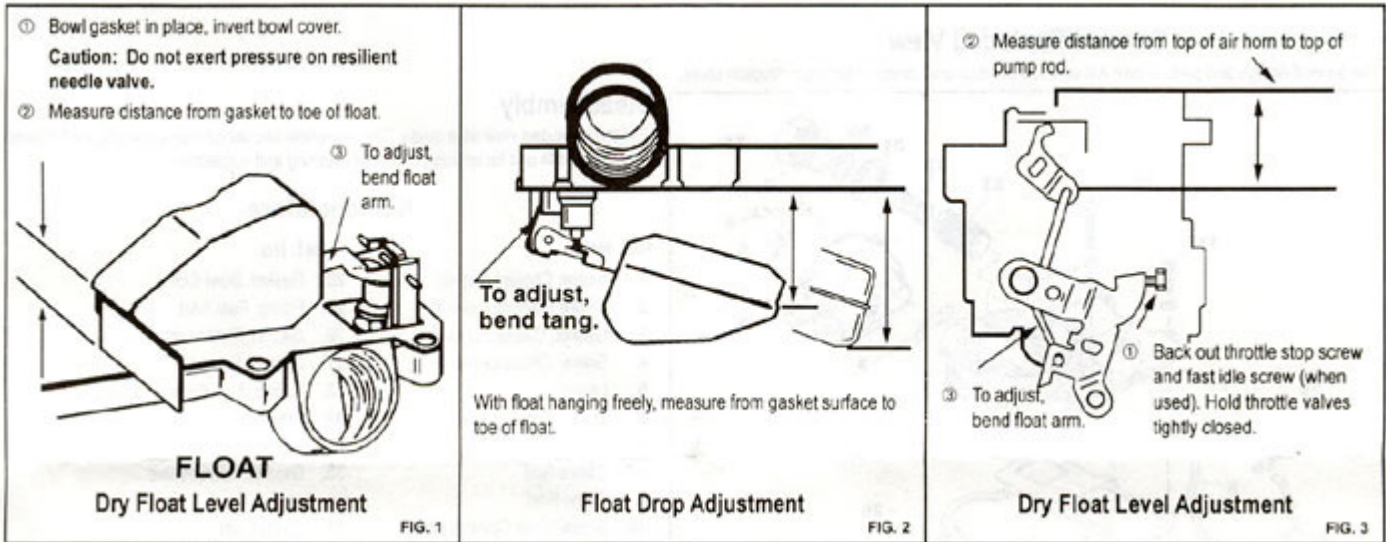

Cyl.	Model/Engine	Carburetor Number	Float Level	Float Drop	Pump Rod	Choke Setting	Choke Unloader	Float Weight
4	MCM 120/140	1389-8490A2						
		Spring – Needle	9/16" (14mm)	1 3/32" (27mm)	29mm	Index	5/64" (2mm)	9 Grams
		Solid – Needle	3/8" (10mm)	1 3/32" (27mm)	29mm	Index	5/64" (2mm)	9 Grams
	MCM 470-170	1389-8489A5	3/8" (10mm)	1 3/32" (27mm)	29mm	Index	5/64" (2mm)	9 Grams
	MCM 2.5L/3.0L	1389-9562A1						
		Spring – Needle	9/16" (14mm)	1 3/32" (27mm)	29mm	Index	5/64" (2mm)	9 Grams
		Solid – Needle	3/8" (10mm)	1 3/32" (27mm)	29mm	Index	5/64" (2mm)	9 Grams
		1389-815396A2	3/8" (10mm)	1 3/32" (27mm)	29mm	Index	5/64" (2mm)	9 Grams
	1389-815397A2	3/8" (10mm)	1 3/32" (27mm)	29mm	Index	5/64" (2mm)	9 Grams	
	1389-8564A1	3/8" (10mm)	1 3/32" (27mm)	29mm	Index	5/64" (2mm)	9 Grams	
	MCM 165/3.7L	3304-9353A2	3/8" (10mm)	1 3/32" (27mm)	29mm	Index	5/64" (2mm)	9 Grams
6	MCM 175/4.3L	3304-9564A1	3/8" (10mm)	1 3/32" (27mm)	29mm	Index	5/64" (2mm)	9 Grams
	MCM 898/200	1389-8488A2	3/8" (10mm)	1 3/32" (27mm)	29mm	Index	5/64" (2mm)	9 Grams
8	MCM 200/5.0L	1389-9563A1	3/8" (10mm)	1 3/32" (27mm)	29mm	Index	5/64" (2mm)	9 Grams
		1389-9670A2	3/8" (10mm)	1 3/32" (27mm)	29mm	Index	5/64" (2mm)	9 Grams

Note: On four cylinder engines experiencing flooding or rough idle, if all components and specifications are okay, it may be necessary to change to the spring – loaded needle and seat assembly. Float level for this type of needle and seat is 9/16" (14mm).