

INSTALLATION INSTRUCTIONS

GIMBAL HOUSING ACCESS PLUG KIT

PART NO. 18-2460

This kit allows for removing and installing the gimbal ring with out removal of the engine and transom assembly. You can locate access holes using the templates included in this instruction sheet. Refer to your engine's service manual for more installation information.

NOTE: It will be necessary to drill access holes in gimbal housing if steering lever cavity is not accessible.

PARTS LIST

Description	Qty.
Pipe Plug	2
Nut, 3/4" - 16	1

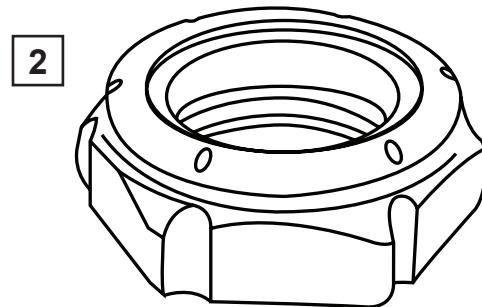
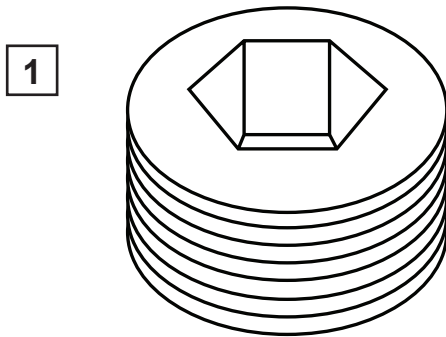

- 1 - Pipe Plug (2)
- 2 - Swivel Shaft Nut

REQUIRED TOOLS

(Not Included in kit)

Description
Hole Saw - 1 1/8"
Tap - 1" NPT #180

TEMPLATES

IMPORTANT: Cut out required template carefully. Make accurate folds using a straight edge. Align centerline with center line of the dimple. After accurately aligned, tape the template to the gimbal housing very securely, preventing it from moving or shifting.

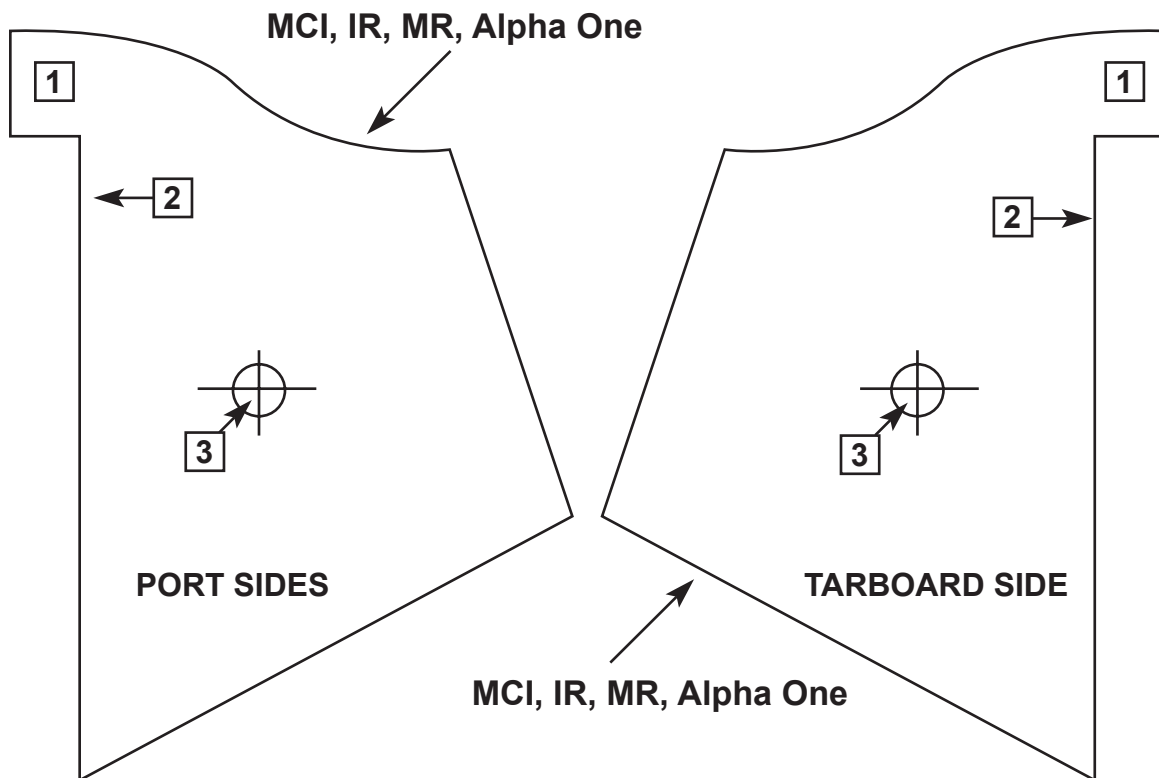

- 1 - Top of template
- 2 - Surface to be placed against gimbal housing lip
- 3 - Center Punch: Use a 1 1/8" (28.5 mm) hole saw to cut the access hole

TEMPLATES

IMPORTANT: Cut out required template carefully. Make accurate folds using a straight edge. Align centerline with center line of the dimple. After accurately aligned, tape the template to the gimbal housing very securely, preventing it from moving or shifting.

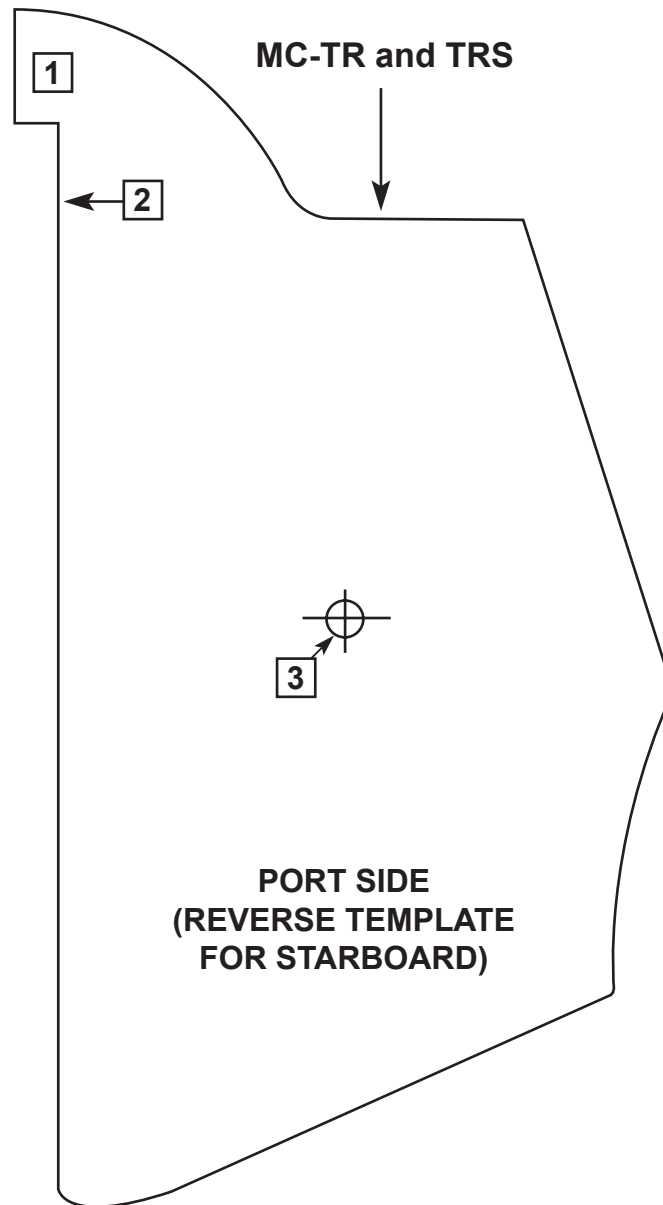

- 1 - Top of template
- 2 - Surface to be placed against gimbal housing lip
- 3 - Center Punch: Use a 1 1/8" (28.5 mm) hole saw to cut the access hole

TEMPLATES

