



FUEL PRIMER SOLENOID KIT, P/N 5007355 INSTALLATION INSTRUCTIONS

APPLICATION

Install fuel primer solenoid kit on the appropriate outboards. DO NOT install on any other models. This kit replaces the following fuel primer solenoids: P/N 437234 and P/N 437231. Refer to the appropriate parts catalog for the original part numbers of service parts.

SAFETY INFORMATION

For safety reasons, this kit should be installed by an authorized *Evinrude[®]/Johnson[®]* dealer. This instruction sheet is not a substitute for work experience. Additional helpful information may be found in other service literature for your engine.

This instruction sheet uses the following signal words identifying important safety messages.

| | | |
|---|---------------|--|
| | DANGER | |
| Indicates an imminently hazardous situation which, if not avoided, WILL result in death or serious injury. | | |

| | | |
|---|----------------|--|
| | WARNING | |
| Indicates a potentially hazardous situation which, if not avoided, CAN result in severe injury or death. | | |

| | | |
|--|----------------|--|
| | CAUTION | |
| Indicates a potentially hazardous situation which, if not avoided, MAY result in minor or moderate personal injury or property damage. It also may be used to alert against unsafe practices. | | |

These safety alert signal words mean:

ATTENTION!
BECOME ALERT!
YOUR SAFETY IS INVOLVED!

IMPORTANT: Identifies information that will help prevent damage to machinery and appears next to information that controls correct assembly and operation of the product.

Always follow common shop safety practices. If you have not had training related to common shop safety practices, you should do so to protect yourself, as well as the people around you.

It is understood that this instruction sheet may be translated into other languages. In the event of any discrepancy, the English version shall prevail.

DO NOT do any repairs until you have read the instructions and checked the pictures relating to the repairs.

Be careful, and never rush or guess a service procedure. Human error is caused by many factors: carelessness, fatigue, overload, preoccupation, unfamiliarity with the product, and drugs and alcohol use, to name a few. Damage to a boat and outboard can be fixed in a short period of time, but injury or death has a lasting effect.

When replacement parts are required, use *Evinrude/Johnson Genuine Parts* or parts with equivalent characteristics, including type, strength and material. Using substandard parts could result in injury or product malfunction.

Torque wrench tightening specifications must be strictly followed. Replace any locking fastener (locknut or patch screw) if its locking feature becomes weak. Definite resistance to turning must be felt when reusing a locking fastener. If replacement is specified or required because the locking fastener has become weak, use only authorized *Evinrude/Johnson Genuine Parts*.

If you use procedures or service tools that are not recommended in this instruction sheet, **YOU ALONE** must decide if your actions might injure people or damage the outboard.



CONTENTS OF KIT

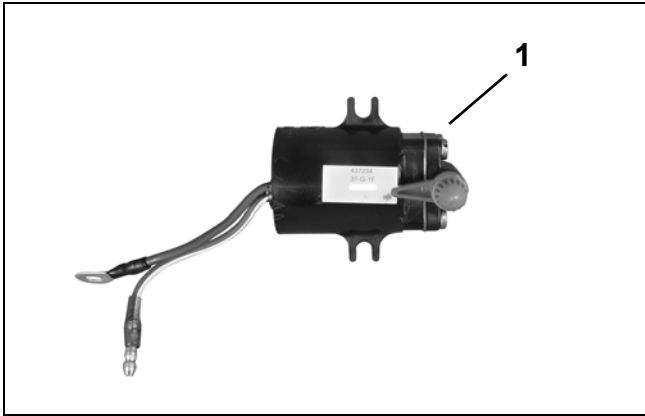

006405

Remove and position cover as needed.



006407

| Ref | P/N | Name of Part | Qty |
|-----|---------|----------------------|-----|
| | 5007355 | PRIMER SOLENOID KIT | |
| 1 | - | *SOLENOID AY, Primer | 1 |

! WARNING !

Protect against hazardous fuel spray. Before starting any fuel system service, carefully relieve fuel system pressure. Refer to Service Manual. To prevent accidental starting while servicing, disconnect battery cables from battery and remove spark plug wires from spark plugs.

! WARNING !

After servicing the fuel system, check for leaks. Failure to check for fuel leakage could allow a leak to go undetected, resulting in fire or explosion.

Make sure no fuel or oil hoses are pinched or restricted.

Prime and pressurize fuel system and check for fuel leaks. Repair all fuel leaks.

Start outboard and check operation. Observe fuel hoses and connections. Repair all fuel leaks.

IMPORTANT: Prior to removal of primer solenoid, note position of all hoses and wiring.

Remove primer solenoid and position on work bench next to service replacement solenoid. Observe electrical terminals. Observe cover orientation and fuel outlet nipples.

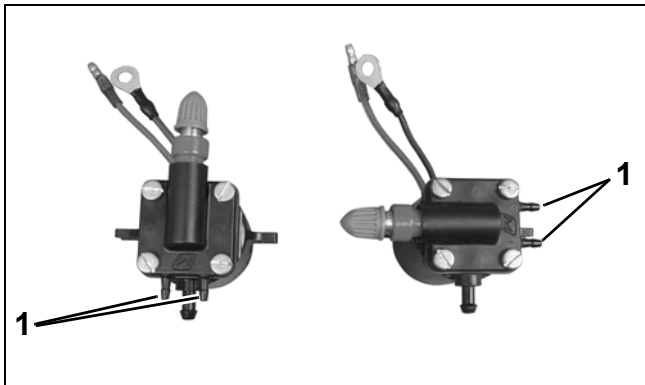

1. Fuel outlet nipples

006406