

# 891730A01

## CARBURETOR FLOAT KIT

### Installation Instructions

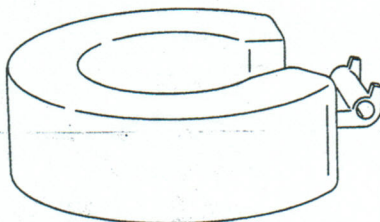

00407

This kit replaces all carburetor floats with the part numbers F10346, FO31554, FO13554, which include the Force and Sport Jet models listed below.

Horsepower	Model Year/Serial Number Range
5	1989 B and UP
9.9	1988 A and Up
15	1990 C and UP
25	0E127700 and UP
35	1990 A and UP
40	1992 C and UP
50	1990 A and UP
70	0E000001 and UP
75	0E138600 and UP
85LD	85LD90C and UP
90	903F90A and UP
90LD	90LD90A and UP
120LD	120LD90B and Up
120	0E000001 and UP
125	1251A89A and UP
150	ALL
90 Sport Jet	ALL
95XR Sport Jet	ALL
120 Sport Jet	ALL
120XR Sport Jet	ALL

**NOTE:** No adjustments to the float level, or float drop are possible with this float kit. Some float installation may show the float less than parallel to the carburetor body. A slight out of parallel float level is acceptable.

1. Should a non parallel float installation have a mid range and/or high speed running problem, check the following.
  - a. The needle used is correct for the carburetor.
  - b. The seat is tight to the carburetor body.

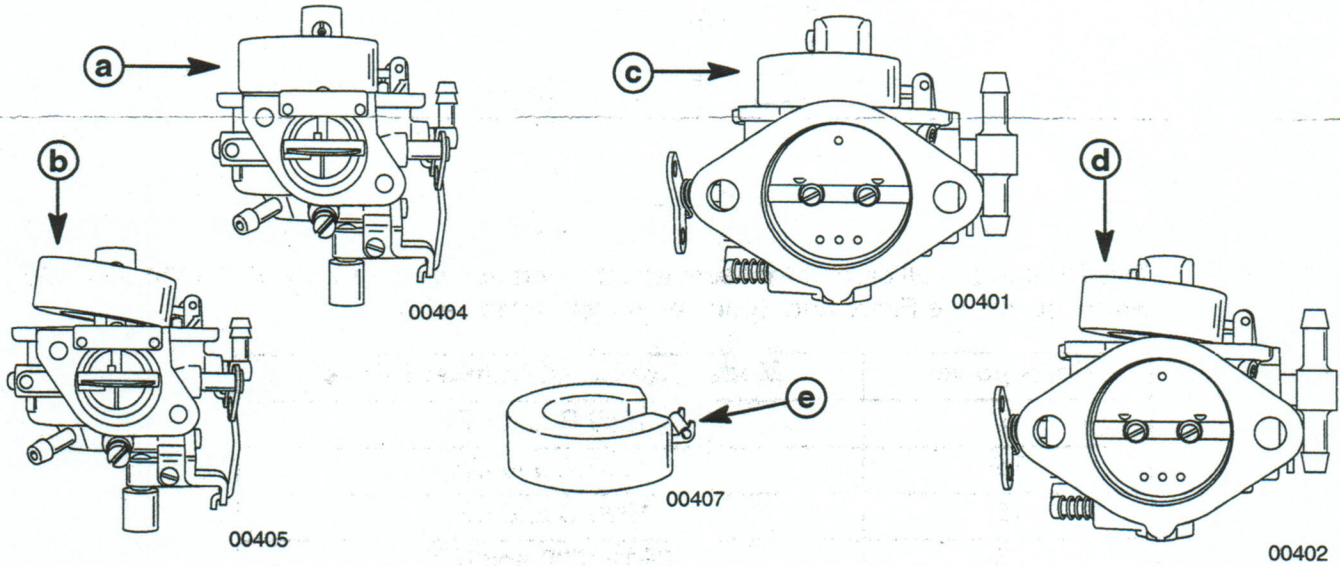

- a - Small bore carburetor with a parallel float
- b - Example of a small bore carburetor with a non parallel float
- c - Large bore carburetor with a parallel float
- d - Example of a large bore carburetor with a non parallel float
- e - Float tang faces towards the float bowl

**NOTE:** Be careful when assembling carburetor. Placing carburetor in a correct operational position without the float bowl secured to the carburetor body will allow the float to swing down and permit the needle to drop out of the carburetor seat.

